

2021-06

# Development of an intelligent tracking system for monitoring rhinos and elephants: A case study of Ngorongoro conservation area

Massawe, Erick

NM-AIST

---

<https://dspace.nm-aist.ac.tz/handle/20.500.12479/1355>

*Provided with love from The Nelson Mandela African Institution of Science and Technology*

**DEVELOPMENT OF AN INTELLIGENT TRACKING SYSTEM FOR  
MONITORING RHINOS AND ELEPHANTS: A CASE STUDY OF NGORONGORO  
CONSERVATION AREA**

**Erick Alphonse Massawe**

**A Dissertation Submitted in Partial Fulfilment of the Requirements for the Degree of  
Doctor of Philosophy in Information and Communication Science and Engineering of the  
Nelson Mandela African Institution of Science and Technology**

**Arusha, Tanzania**

**June, 2021**

## **ABSTRACT**

Events such as poaching, accidents, unexpected adverse health events (e.g., heart problems, seizures, heart stroke, dizziness, breathing problems, bleeding and broken bones) have adverse impact on animals' health. Many of such events, if known to someone in a position to assist the animal, can be avoided, minimized or ameliorated. Unfortunately, many events occur in a manner in which assistance is unavailable or provided too late. In regard to this, measures needed include improving systems and methods for avoiding or reducing the impact of such adverse events.

The study developed an intelligent real-time tracking system for monitoring rhinos and elephant. It was guided by four specific objectives: reviewing and analyzing the existing systems for tracking animals and proposing new more intelligent systems, designing of smart sensing system for animal emotions recognition, developing computational models' analysis of wildlife tracking system for optimality, and developing an intelligent wildlife collar information management system using mobile application. The first objective was accomplished by conducting a cross-sectional study, and one-time data collection at Ngorongoro Conservation Area, Tanzania. The second objective was completed by designing a modern smart sensing animal collar belt that can recognize animal emotions. The third objective was performed by attenuation models-based analysis of wildlife tracking system for optimality. And the fourth objective was accomplished by developing a mobile application that collects periodical sensor output responses from tracked elephant/rhino with their GPS locations.

All developed solutions were promising and can be utilized on improvement of the current existing ant-poaching system. The solutions can be considered as a proof of concept, which needs to be developed further for use in final product.

## DECLARATION

I, Erick Alphonse Massawe do hereby declare to the Senate of Nelson Mandela African Institution of Science and Technology that this dissertation is my own original work and that it has neither been submitted nor being concurrently submitted for a degree award in any other institution.

Erick Alphonse Massawe  \_\_\_\_\_

Name and signature of candidate

Date

The above declaration is confirmed

Dr. Kisangiri Michael \_\_\_\_\_

Name and signature of supervisor 1

Date

Dr. Shubi kaijage \_\_\_\_\_

Name and signature of supervisor 2

Date

Prof. Padmanabhan Seshaiyer  \_\_\_\_\_ 19/4/2021

Name and signature of supervisor 3

Date

## **COPYRIGHT**

This dissertation is copyright material protected under the Berne Convention, the Copyright Act of 1999 and other international and national enactments, in that behalf, on intellectual property. It must not be reproduced by any means, in full or in part, except for short extracts in fair dealing; for a researcher's private study, critical scholarly review or discourse with an acknowledgement, without a written permission of the Deputy Vice Chancellor for Academic, Research and Innovation, on behalf of both the author and the Nelson Mandela African Institution of Science and Technology.

## CERTIFICATION

The undersigned certify that, they have read and hereby recommend for acceptance by the Nelson Mandela African Institution of Science and Technology a dissertation titled *“Development of an Intelligent Tracking System for Monitoring Rhinos and Elephants: A case Study of Ngorongoro Conservation Area”* in partial fulfilment of the requirements for the degree of doctor of philosophy in Information and Communication Science and Engineering of the Nelson Mandela African Institution of Science and Technology.

Dr. Kisangiri Michael \_\_\_\_\_

Name and signature of supervisor 1

Date

Dr. Shubi kaijage \_\_\_\_\_

Name and signature of supervisor 2

Date

Prof. Padmanabhan Seshaiyer  \_\_\_\_\_ 19/4/2021

Name and signature of supervisor 3

Date

## **ACKNOWLEDGEMENTS**

First of all, I am grateful to Almighty God for His guidance for the whole period of my studies.

I would like to express my sincere gratitude to all individuals who, in one way or another, provided their assistance during my study. I am indebted thankful to my supervisors Dr. Kisangiri Michael, Dr. Shubi Kaijage and Prof. Padmanabhan Seshaiyer for accepting and taking up the role of supervising my research. They remained patient and performed a thorough work for the whole period of accomplishing this scholarly work.

I am grateful to the NM-AIST community and the government of the United Republic of Tanzania for offering me a scholarship and supportive environment for the accomplishment of this study.

Special thanks should also go to my family and my parents for their endless prayers and encouragement, including moral support throughout my basic education to higher education.

**DEDICATION**

-----*To my Family*-----



## TABLE OF CONTENTS

|   |     |
|---|-----|
| ABSTRACT .....  | i   |
| DECLARATION .....   | ii  |
| COPYRIGHT .....   | iii |
| CERTIFICATION.....  | iv  |
| ACKNOWLEDGEMENTS .....  | v   |
| DEDICATION .....  | vi  |
| TABLE OF CONTENTS .....   | vii |
| LIST OF TABLES .....  | xi  |
| LIST OF FIGURES.....  | xii |
| LIST OF APPENDICES .....  | xiv |
| LIST OF ABBREVIATIONS AND SYMBOLS .....   | xv  |
| CHAPTER ONE .....   | 1   |
| General Introduction .....  | 1   |
| 1.1 Background of the Problem .....   | 1   |
| 1.2 Statement of the Problem.....   | 2   |
| 1.3 Rationale of the Study.....   | 2   |
| 1.4 Research Objectives .....   | 3   |
| 1.4.1 General Objective.....  | 3   |
| 1.4.2 Specific Objectives.....  | 3   |
| 1.5 Research Questions .....  | 3   |
| 1.6 Significance of the Study .....   | 3   |
| 1.7 Delineation of the Study .....  | 4   |
| CHAPTER TWO.....  | 5   |
| An Intelligent Real-Time Wireless Sensor Network Tracking System for Monitoring Rhinos and Elephants in Tanzania National Parks: A Review ..... | 5   |
| Abstract .....  | 5   |
| 2.1 Introduction.....   | 5   |
| 2.2 Background of Problem .....   | 6   |
| 2.3 Related Work .....  | 6   |
| 2.3.1 Field Experience on Elephants Collaring Project at Ruaha National Park .....  | 10  |
| 2.4 Motivation.....   | 10  |
| 2.5 An Intelligent Tracking and Monitoring System .....   | 11  |
| 2.6 Proposed System Infrastructure .....  | 11  |

|  |  |    |
|--|--|----|
| 2.6.1  | Communication Channel.....                   | 11 |
| 2.6.2  | A central Computer System .....              | 11 |
| 2.6.3  | Sensors Network .....                        | 11 |
| 2.6.4  | Cellular Smartphone.....                     | 12 |
| 2.7  | System Operation.....                        | 12 |
| 2.8  | Discussion .....                             | 13 |
| 2.9  | Conclusion and Recommendations .....         | 13 |
| CHAPTER THREE.....   |  | 15 |
| Design and Analysis of Smart Sensing System for Animal Emotions Recognition.....                                       |  | 15 |
| Abstract .....   |  | 15 |
| 3.1  | Introduction.....                            | 15 |
| 3.2  | Related Works.....                           | 16 |
| 3.3  | Cattle and Dog Behaviors .....               | 17 |
| 3.4  | System Design.....                           | 18 |
| 3.5  | Heart Rate Sensor.....                       | 18 |
| 3.6  | Body Temperature Sensor.....                 | 20 |
| 3.7  | Microcontroller Overview.....                | 21 |
| 3.8  | Communication.....                           | 22 |
| 3.9  | Circuit Simulation Results .....             | 22 |
| 3.10   | Circuit Simulation Output.....               | 23 |
| 3.11   | Hardware Model .....                         | 24 |
| 3.12   | Data Collection .....                        | 26 |
| 3.13   | Results and Discussion.....                  | 27 |
| 3.14   | Conclusion and Recommendations .....         | 27 |
| CHAPTER FOUR.....  |  | 29 |
| Computational Models Analysis of Wildlife Tracking System for Optimality: A Case Study of Ngorongoro Conservancy ..... |  | 29 |
| Abstract .....   |  | 29 |
| 4.1  | Introduction.....                            | 29 |
| 4.2  | Proposed Tracking System.....                | 31 |
| 4.2.1  | Wireless Sensor Networks .....               | 32 |
| 4.2.2  | Global Positioning System.....               | 33 |
| 4.2.3  | Global System for Mobile Communication ..... | 34 |
| 4.3  | Ngorongoro Conservation Environment.....     | 35 |
| 4.3.1  | Elephants and Rhinos Movements .....         | 36 |

|   |   |    |
|---|---|----|
| 4.3.2   | Vegetation Cover.....                                     | 40 |
| 4.3.3   | Atmospheric Characteristics .....                         | 40 |
| 4.3.4   | Terrain Profile .....                                     | 42 |
| 4.4   | Signals and Attenuations.....                             | 44 |
| 4.4.1   | Signals .....   | 44 |
| 4.4.2   | Attenuations .....  | 44 |
| 4.5   | Measurement Setup.....                                    | 44 |
| 4.5.1   | Vegetation Attenuation .....                              | 45 |
| 4.5.2   | Atmospheric Attenuation .....                             | 57 |
| 4.5.3   | Terrain Models .....                                      | 61 |
| 4.5.4   | International Telecommunication Union Terrain Model ..... | 62 |
| 4.5.5   | Longley Rice Model.....                                   | 63 |
| 4.6   | Multi-objective Optimization of the Model .....           | 64 |
| 4.7   | Results and Discussions .....                             | 66 |
| 4.8   | Conclusion .....  | 67 |
| CHAPTER FIVE.....   |   | 68 |
| A Mobile Platform for Wildlife Conservation and Research Information Management with Real-Time Monitoring ..... |   | 68 |
| Abstract .....  |   | 68 |
| 5.1   | Introduction.....   | 68 |
| 5.2   | Related Works.....  | 69 |
| 5.1.1   | Rhino Security, Monitoring and Management System .....    | 69 |
| 5.1.2   | Tracking Real Time Monitoring .....                       | 70 |
| 5.1.3   | Design of Elephant Collars to Reduce Crop Foraging.....   | 70 |
| 5.3   | Existing System.....                                      | 71 |
| 5.4   | Proposed System.....                                      | 71 |
| 5.5   | Design .....  | 71 |
| 5.5.1   | Algorithm explanation.....                                | 72 |
| 5.5.2   | Modules of proposed system.....                           | 72 |
| 5.5.3   | Component Diagram .....                                   | 73 |
| 5.5.4   | Actor of Proposed System.....                             | 74 |
| 5.5.5   | Implementation.....                                       | 75 |
| 5.6   | Testing.....  | 76 |
| 5.7   | Results and Discussions .....                             | 76 |
| 5.8   | Android App Output .....                                  | 76 |

|   |                                      |     |
|---|--------------------------------------|-----|
| 5.8.1   | Ranger .....                         | 81  |
| 5.8.2   | Veterinarian .....                   | 81  |
| 5.8.3   | Researcher .....                     | 81  |
| 5.9   | Conclusion and Recommendations ..... | 86  |
| CHAPTER SIX .....                                       |                                      | 87  |
| General Discussion, Conclusion and Recommendation ..... |                                      | 87  |
| 6.1   | General Discussion .....             | 87  |
| 6.2   | Conclusion .....                     | 89  |
| 6.3   | Recommendations .....                | 90  |
| REFERENCES .....  |                                      | 91  |
| APPENDICES .....  |                                      | 105 |
| RESEARCH OUTPUTS .....                                  |                                      | 111 |

## LIST OF TABLES

|          |  |    |
|----------|--|----|
| Table 1: | Estimation of <b><i>Am</i></b> based on Equation (7): Sample Experiments ..... | 51 |
| Table 2: | Nominal Clutter Heights and Distances.....                                     | 53 |
| Table 3: | Constant Values for Equation (6) .....   | 55 |

## LIST OF FIGURES

|            |  |    |
|------------|--|----|
| Figure 1:  | Massive Elephants Tusk and Rhinos' Horns Collected after have been Poached (Laing, 2015).....    | 2  |
| Figure 2:  | Elephants Collaring at Ruaha National Park in Tanzania.....                                      | 10 |
| Figure 3:  | A Proposed Illustration of an Early Warning System.....  | 12 |
| Figure 4:  | The PSL-iECG2 (Mini-size 2ch ECG Sensor Module with Isolation).....                              | 20 |
| Figure 5:  | Proteus Circuit Simulation Schematic for Anti-poaching System.....                               | 23 |
| Figure 6:  | Circuit Simulation Output.....   | 24 |
| Figure 7:  | System Model with the Sensors and Electrodes .....   | 25 |
| Figure 8:  | Model of the Solar Powered Collar Belt.....  | 25 |
| Figure 9:  | A prototype Collar Belt.....   | 26 |
| Figure 10: | Panic and Normalization of Dog's Heartbeat and Temperature .....                                 | 27 |
| Figure 11: | Ngorongoro Conservation Area Map (NCA, 2014) .....   | 30 |
| Figure 12: | Proposed Wildlife Tracking System Scope .....  | 31 |
| Figure 13: | Cellular Part of Tracking System.....  | 32 |
| Figure14:  | Tanganyet Corridor; A Corridor Identified using Satellite by World Elephant Centre (2008) .....  | 37 |
| Figure 15: | Upper Kitete/Selela Corridor (TAWIRI, 2009).....   | 38 |
| Figure 16: | Rhino Distribution Across Crater during Wet and Dry Seasons (Gadiye, 2016) .                     | 39 |
| Figure 17: | The Ngorongoro Conservation Area Rainfall and Temperature Characteristics (Briggs, 2012) .....   | 42 |
| Figure 18: | Ngorongoro Conservation Aarea Terrain Overview (Google Earth) .....                              | 43 |
| Figure 19: | Specific Attenuation due to Woodland (V: Vertical Polarization, H: Horizontal Attenuation) ..... | 50 |
| Figure 20: | Signal through Vegetation Path Geometry .....  | 56 |
| Figure 21: | Fitness value against generation for the algorithm .....   | 66 |
| Figure 22: | Architecture Diagram.....  | 72 |
| Figure 23: | Component diagram.....   | 73 |
| Figure 24: | Data Flow Diagram.....   | 75 |
| Figure 25: | Smart Sensing Animal Collar Belt Home Page of App.....   | 77 |
| Figure 26: | System Menu .....  | 78 |
| Figure 27: | Animal Types.....  | 79 |
| Figure 28: | Dashboard .....  | 80 |
| Figure 29: | System user's Registration.....  | 82 |

|  |    |
|--|----|
| Figure 30: Smart Sensing Collar Belt Details .....         | 84 |
| Figure 31: Report Generation .....                         | 85 |
| Figure 32: Five Fundamental Steps in Design-Thinking ..... | 87 |

## LIST OF APPENDICES

|             |   |     |
|-------------|---|-----|
| Appendix 1: | Entry Permit to Ngorongoro Area Authority ..... | 105 |
| Appendix 2: | Sample Coding .....                             | 106 |



## LIST OF ABBREVIATIONS AND SYMBOLS

|          |   |
|----------|---|
| ABC      | Animal Behavior Classification                                    |
| BTS      | Base Transceiver Station  |
| C++      | An Object-oriented Programming Language Based On C                |
| CDMA     | Code Division Multiple Access                                     |
| CITES    | Convention on International Trade in Endangered Species           |
| CMOS     | Complementary Metal-Oxide Semiconductor                           |
| CSIR     | Council for Scientific and Industrial Research                    |
| DNA      | Deoxyribonucleic Acid   |
| FORTTRAN | Formula Translation   |
| GPS      | Global Positioning System   |
| GSM      | Global System Mobile  |
| GSR      | Galvanic Skin Response  |
| ICCF     | International Conservation Caucus Foundation                      |
| IMEI     | International Mobile Equipment Identity                           |
| ISM band | Industrial, Scientific and Medical radio band                     |
| ITM      | Irregular Terrain Model   |
| ITS      | Institute for Telecommunication Sciences                          |
| ITU-R    | International Telecommunication Union, Radio communication Sector |
| LAN      | Local Area Network  |
| MBS      | Mobile Biological Sensor  |
| MCS      | Master Control Station  |
| MEO      | Medium Earth Orbit  |
| NCA      | Ngorongoro Conservation Area                                      |
| NCAA     | Ngorongoro Conservation Area Authority                            |
| NTIA     | The National Telecommunications and Information Administration    |
| PDA's    | Personal Digital Assistant  |
| PIR      | Passive Infrared  |
| PPS      | Precise Positioning Service                                       |
| PRN      | Pseudo Random Noise   |
| RET      | Radiative Energy Transfer   |
| RF       | Radio Frequency   |
| RPAS     | Remotely Piloted Aircraft Systems                                 |
| SPS      | Standard Positioning Service                                      |

|             |   |
|-------------|---|
| TAWIRI      | Tanzania Wildlife Research Institute  |
| TDMA        | Time Division Multiple Access   |
| TeX         | Tau Epsilon Chi   |
| UASs        | Unmanned Aerial Systems   |
| UAVs        | Unmanned Aerial Vehicles  |
| UNEP        | United Nations Environmental Programmes   |
| URA         | Interpreting User Range Accuracy  |
| USAF        | U.S. Air Force  |
| UTD         | Uniform Theory of Diffraction   |
| Vsat        | Very small aperture terminal  |
| WEC         | World Elephant Center   |
| WSN         | Wireless Sensor Network   |
| WWF         | World Wildlife Funds  |
| $L_{r,eff}$ | Effective path length through the rain cell   |
| $d$         | Height of the base antenna  |
| $\gamma$    | Length of path within woodland (m)  |
| $A_m$       | Maximum attenuation for one terminal within a specific type and depth of vegetation (dB). |
| $G_b$       | Gain of the base antenna  |
| $h_m$       | Gain of the mobile antenna  |
| $\omega$    | Physical width of the vegetation  |
| dB          | Vegetation in a radio path  |
| dB/m        | Specific attenuation rate   |
| $d_k$       | Distance from the antenna   |
| $f$         | Frequency   |
| $h_a$       | Nominal clutter height  |
| $\alpha$    | Average of attenuation  |
| $\theta$    | Elevation angle of the path   |
| $\lambda$   | Lambda indicates the wavelength of any wave   |
| $\tau$      | Polarization tilt angle   |

## CHAPTER ONE

### General Introduction

#### 1.1 Background of the Problem

Poaching dwindled the 1.3 million population of African elephants in 1979 to 500 000 elephants by 1987, as it is remarked by University of Washington (2013). The University further stressed that the situation impelled the listing of African elephants as endangered species (Appendix I) by the Convention on International Trade in Endangered Species (CITES) in 1989. Wildlife groups estimate that 10 000 to 25 000 elephants are killed in Tanzania each year for ivory tusks and the number of elephants in southern Tanzania has fallen by more than half. Also, based on the African elephant ivory amounting to 46.5 tons apprehended in 2011, they estimate the number of elephants killed in a year to be as high as 50 000; with an approximate of 400 000 surviving elephants in Africa, it might take up to just the next decade for their virtual extinction (Sen, 2013).

The world is curbing with this exceptional spike in illegal wildlife trade, threatening to overturn decades of conservation and development gains (Fig. 1). As both populations and economies have grown in East Asia, the demand for wildlife products has surged, increasing the market price of ivory and rhino horn. The recent rise in prices of wildlife product has been caused by the increase of more planned, well-funded and well-armed criminal and terrorist networks and even soldiers, compounding the challenges faced by those charged with protecting the wildlife. Wildlife products can easily be transformed into cash and used to purchase weapons and fund violent operations, and have become a substantial source of income for terrorist organizations in Africa (International Conservation Caucus Foundation [ICCF], 2013). Asian demand for rhino horn has set a historic price for rhino horn powder over \$30 000 per pound, making it more valuable than gold and cocaine (Massawe *et al.*, 2017). Rhino poaching rates in Africa have risen since the beginning of the decade (ICCF, 2013), it is estimated that 500 rhinos a year are poached in South Africa alone, despite increased surveillance efforts in South African natural reserves, setting a new national record of rhino killings.

Since 2002 when international monitors started keeping records, 2011 was marked as the year that elephant poaching hit the highest levels, and the amount of ivory seized was recorded as the highest since 1989. The trend, based on the first half of 2012 estimates, provided no hopes of slowing down, and in early 2013, about 450 elephants (nearly 10% of the country's whole

elephant population) were killed in the Cameroon's National Park alone (ICCF, 2013). High profit margins, weak efforts in enforcing the law and poor governance are the factors leading to the thriving of illegal wildlife trade, and it has gone hand in hand with the rise in other Chinese investments in Africa. Ineffective laws, weak judicial systems and light punishments lead to the well-organized mafia-like criminal networks to thrive in this illegal wildlife trade that involves shipping animal parts from Africa to Asia by paying off wildlife agents, customs officials and government leaders (ICCF, 2013).



**Figure 1: Massive Elephants Tusk and Rhinos' Horns Collected after have been Poached (Laing, 2015)**

### **1.2 Statement of the Problem**

Illegal poaching of rhino's and elephants is a threat to global ecosystem due to the disappearance of some species. Many systems have been developed but with different engineering trade-offs that only show location of animals at a particular time. However, there is no reported designed intelligent system that can monitor rhinos and elephants at the fear stage before being killed by the poachers. Hence, there is a need for developing an intelligent sensor tracking system in order to curb the problem of rhinos and elephants poaching.

### **1.3 Rationale of the Study**

Elephant and rhino poaching monitoring is still a challenge in our continent. The number of this species is highly decreasing daily. Though different operations and monitoring systems have been implemented by the national park authorities, but still monitoring and tracking of the elephants and rhinos is a big problem for the African continent. Currently, Tanzanian elephants are tracked using satellite tracking collars and rhinos are monitored using radio frequency

tracking system, binoculars and networked sensors embedded directly in their horns in order to allow park rangers to monitor the animals (Gaworecki, 2017). Some other countries are using systems like drones yet they fail to combat poaching.

## **1.4 Research Objectives**

### **1.4.1 General Objective**

The main objective of this study was to develop an intelligent real-time tracking system for monitoring rhinos and elephants.

### **1.4.2 Specific Objectives**

- (i) To review and analyze the existing systems.
- (ii) To design a smart sensing system for animal emotions recognition.
- (iii) To develop computational models analysis of wildlife tracking system for optimality.
- (iv) To develop an intelligent wildlife collar information management system.

## **1.5 Research Questions**

This study was guided by the following research questions:

- (i) How do the current systems for tracking rhinos and elephants work?
- (ii) Which kind of sensors can be used to design animal emotions recognition system?
- (iii) How optimality can be achieved on wildlife tracking system?
- (iv) Which platform is suitable for collection and analysing information from sensors periodically?

## **1.6 Significance of the Study**

This research is a contribution to the knowledge on wireless sensor network and poaching systems. The output, that is, an intelligent real-time wireless sensor network tracking system will ensure security and safety to the rhinos/elephants in Tanzanian national parks. Likewise, the system will accelerate the rate of scientific data collection and analysis that will ensure timely monitoring of the animals' health. This study is guided by the theory of Social Construction of Technology (Scott) in which the key argument is that technology does not determine human action, but rather, human action shapes technology. That is, the way

technology is used cannot be understood without understanding how that technology is embedded in its social context.

## **1.7 Delineation of the Study**

In the past few years, illegal poaching activities have highlighted the importance of monitoring the movement and well-being of endangered species. In this work, development of low-cost Geo-location modules attached to the animal and the deployment of portable Geo-mode monitoring stations that scan barcodes attached to the animals and deliver this information to a base station are investigated.

The system works by putting one microchip in the rhino horn /elephant tusk and the second in its body. The microchip in the body is synchronized with the horns microchips. In response to this, once a horn is removed, investigators will be able to make tracking. Also, a microchip for measuring body temperature, skin resistance and heart rate pulses will be positioned on the animal body for measuring animal's fear before being attacked by poachers. A Geo-mode monitoring station is built in the controlled national park for scanning and monitoring all microchips. The software platform that integrates this geospatial information together with animal information to provide an effective tool for monitoring and management is developed.

## CHAPTER TWO

### **An Intelligent Real-Time Wireless Sensor Network Tracking System for Monitoring Rhinos and Elephants in Tanzania National Parks: A Review**

#### **Abstract**

The advancement of wireless sensor networks yields a variety of wireless sensor network for wildlife tracking. One typical application for wireless sensor networks is in animal tracking and monitoring in wildlife environments. A significant number of studies has been done in tracking animals with sensor networks. However, from the recent literature it is observed that there is no study which has been done on an intelligent real-time sensor network that is capable to alerting the rangers an incidence of animal poaching before it occurs. In this research an intelligent wireless sensor system for tracking and monitoring rhinos and elephants is proposed.

---

<sup>1</sup>*This chapter is based on: E. Massawe, M. Kisangiri, S. Kaijage and P. Seshaiyer, "An intelligent real-time wireless sensor network tracking system for monitoring rhinos and elephants in Tanzania national parks: a review" International Journal of Advanced Smart Sensor Network Systems (IJASSN), Vol 7, No.4, October 2017.*

#### **2.1 Introduction**

A Wireless Sensor Networks (WSN) is defined as a network of wireless devices, called as nodes which sense given objects or entities and communicate the sensed data through wireless links (Conti *et al.*, 2008). The data are transmitted via a single hop or multi-hops, to a control centre which can be connected to other networks, for example, Global System for Mobile communication (GSM). A wireless sensor node consists of one or more sensors for sensing physical variables, main processing unit (a microcontroller or low-power consuming processor), analog-to-digital converter (ADC), flash memory and radio frequency (RF) transceiver (Chen & Wang, 2008; Barth, 2009; Choi & Zhou, 2010). Wireless sensor networks have recently come into prominence because of its potential in revolutionizing many aspects of the economy and day to day life from environmental monitoring, to the health care industry, manufacturing etc. Sensors are often deployed in constrained environments such as rain forests, mountains or construction sites for monitoring or detecting particular events (Estrin, 2002; Ganesan, 2004; Elson & Estrin, 2004).

## **2.2 Background of Problem**

Poaching decimated African elephant populations from approximately 1.3 million to 500 000 individuals from 1979 to 1987 (University of Washington, 2013). This prompted the Convention on International Trade in Endangered Species (CITES) to list the African elephants as endangered species in 1989. Despite these protections, a higher percentage of the remaining Africa's elephants are now being killed than ever before (University of Washington, 2013). Wildlife groups estimate that 10 000 to 25 000 elephants are killed in Tanzania each year for their ivory tusks and the number of elephants in southern Tanzania has fallen by more than half. Also, they estimate that as many as 50 000 elephants are currently being killed annually based on the 46.5 tons of African elephant ivory seized in 2011; approximately 400 000 elephants remaining in Africa, and they could be virtually extinct in the next decade (Sen, 2013).

The world is curbing with this exceptional spike in illegal wildlife trade, threatening to overturn decades of conservation and development gains. As both populations and economies have grown in East Asia, the demand for wildlife products has surged, increasing the market price of ivory and rhino horn.

Asian demand for rhino horn has set a historic price for rhino horn powder - over \$30 000 per pound, making it more valuable than gold and cocaine (Massawe *et al.*, 2017). Rhino poaching rates in Africa have risen since the beginning of the decade. About 500 rhinos a year are poached in South Africa alone, despite increased surveillance efforts in South African nature reserves, setting a new national record of rhino killings (ICCF, 2013). In 2011, elephant poaching levels in Africa were at their highest since international monitors began keeping detailed records in 2002, and recorded ivory seizures are at their highest levels since 1989. Estimates from the first half of 2012 provide little reason to think the trend will slow down any time soon. In year 2013 nearly 450 elephants were slaughtered in Cameroon's National Park, representing close to 10% of that country's remaining elephant population (ICCF, 2013).

## **2.3 Related Work**

This research suggests the use of animal attached with certain type of sensors and forming an intelligent tracking and monitoring system that can be able to send information to the rangers when the animal is on fear condition or horns removed. Many scientific studies have put more efforts on development of systems that can only report to the rangers after the incidence of poaching had happened. Therefore, both the use of sensors to form an intelligent tracking and



monitoring of rhinos and elephants, existing anti-poaching systems and animal tracking and monitoring systems are to be investigated.

A study by Margarita (2014) proposed use of Remotely Piloted Aircraft Systems as a Rhinoceros Anti-Poaching Tool in Africa following high poaching prevalence in South Africa. Remotely Piloted Aircraft Systems (RPAS), sometimes also referred as Unmanned Aerial Vehicles (UAVs), Unmanned Aerial Systems (UASs) or drones (the ones for military purposes), are aircrafts (fixed or rotary wings) that are equipped with cameras and or other sensors and can be sent (using manual, semiautomatic or automatic control) to a destination to gather information. The study area consisted of several large game farms in KwaZulu-Natal province, South Africa, and the targets were better detected at the lowest altitudes, but to operate the plane safely and in a discreet way, altitudes between 100 and 180 m were the most convenient; and it was established that the low cost of €14 000 per flight, RPAS can be useful for rhinoceros stakeholders for field control procedures despite its little limitations in the integration of anti-poaching battle (Margarita, 2014). In respect to this study based on the Tanzanian environment, more considerations are made in order to have a better system for anti-poaching in relation to Ngorongoro Conservation Area.

Another anti-poaching research work has been conducted in Kenya with the aid of World Wildlife Fund (WWF). This study involved placement of specialized rhino horn tracking systems combined with forensic DNA technology which allows for 100% traceability of every rhino horn and live animal within Kenya. In the DNA study for anti-poaching involved embedding microchips into the horn of every rhinoceros in Kenya in a bid to keep the declining population safe from the ever-increasing presence of poachers. The microchips in the horns of rhinos may discourage poachers from trying to smuggle the contraband out of Kenya. When a rhino is killed and the horn is chopped off and taken away, if this horn is seized and the microchip tag can be identified, it can be traced back to a killed animal and it can actually show and verify that it was a poaching incident (World Wildlife Fund, 2013). The approach presented in this study was to reveal poaching incidents after happening which is not worth enough since already poaching incidents had occurred as it is contended in by Patrovsky and Biebl (2005).

A study by Banzi (2014) on employing a modern and sophisticated technology presents the ideal system for curbing poaching prevalence. In this system, animals are mounted with sensors and act as Mobile Biological Sensors (MBS). Sensor fusion incorporating visual infrared camera and Global Positioning System (GPS) for transmission of location details of MBS, central computer

system for classification of animal actions and wireless communication's access points (Banzi, 2014). It is furthermore remarked by Banzi (2014) that the system proposes three different actions of responses. In the first action, animals' location data from the GPS are continuously received by the access points at set time intervals and the collected data classified and analysed to see whether there is a sudden panic due to fear by the animal groups. This is referred to as Animal Behaviour Classification (ABC). Visualization is the second action. It involves processing obtained images of the surroundings of the animal groups by using different image processing techniques in order to get a good understanding of the cause of animal group's sudden movements. The third action involves sending messages with information about the animals panic due to fear and their location to the game ranger's cellular phone using the Global System Mobile (GSM) network (Banzi, 2014).

This proposed system has many drawbacks and is not efficient due to the following; for example, if the animal with the camera moved away from the group it is not possible to know what will happen. Rhinos and elephants not necessarily move in groups, and for this case, those animals which will be walking alone will not be protected. The sending of the images needs a network with high bandwidth so as to send the data with less delaying. It is very difficult to take pictures in dense forest and populated areas. Also the camera consumes much power; hence the cameras that have batteries with long life span are expensive and needs to be charged frequently.

Another study conducted by Rebecca (2009) on remote monitoring of animal behaviour in the environment can assist in managing both the animal and its environmental impact. The GPS collars which record animal locations with high temporal frequency allow researchers to monitor both animal behaviour and interactions with the environment (Matthews *et al.*, 2013). These ground-based sensors can be combined with remotely-sensed satellite images to understand animal landscape interactions. The key to combining these technologies is communication methods such as wireless sensor networks (WSNs). The author explores this concept using a case study from an extensive cattle enterprise in northern Australia and demonstrates the potential for combining GPS collars and satellite images in a WSN to monitor behavioural preferences and social behaviour of cattle (Rebecca, 2009). However, this concept cannot be implemented for poaching monitoring since satellite is very expensive and a specific satellite should be positioned to monitor specific area.

Another study by Bagree *et al.* (2010) suggested the use of Wireless Sensor Network (WSN) in combination with image sensors opens plethora for wildlife tracking. It provides a glimpse into

previously unseen, remote and inaccessible world of some of the most endangered species on earth. The TigerCENSE is such an attempt to put sensor network technology in conserving one of the rarest and most elusive big cat species. The node, triggered by the Passive Infrared (PIR) sensor, captures the image of a tiger using a Complementary metal–oxide–semiconductor (CMOS) image sensor and stores it in an external memory chip (Bagree *et al.*, 2014). However, to avoid any disturbance to the animals, the node uses an Infrared (IR) flash, instead of white flash in order to illuminate the target at night. The stored images get transferred to the base station via radio transceiver; it is transferred to the database server through Internet links for analysis by wildlife researchers. A solar energy harvesting system for recharging node's batteries is being added to avoid frequent human visits to change the batteries, making it highly non-intrusive system (Bagree *et al.*, 2010). This technology if applied for the rhinos and elephants monitoring it will not work efficiently due to the following reasons; many cameras will be required throughout the national park; processing of image data requires enough bandwidth and also the cameras do not work properly during night hours and in thick forest.

In addition to these, there is another important research which is similar to the study presented in this paper. Using biometric sensors to monitor the animal body parameters is not a new idea, but it has been limited to a few of incident types. For example, Zhang (2010) described a distributed system for mad-cow monitoring and tracking. He proposed the use of the tiny sensor device which is able to detect virus, read the current level of body temperature, measure the heart-beating rate and blood pressure for each cow. He proposed Base stations to be used for data processing since it has higher processing capability and more energy source such as personal digital assistant (PDA). And they are installed in the barn, stones or trees in the grass field, in the transportation trucks and slaughtering houses. All base stations, grouped into a local monitoring network can forward information to a central base station which connects with the Internet and can save the information or forward it to the control centre. The proposed system can provide disease detection and safety processing monitoring (Zhang, 2010).

### 2.3.1 Field Experience on Elephants Collaring Project at Ruaha National Park

The World Elephant Centre (WEC) were invited in October 2016 for elephants collaring programme at Ruaha National Park. The main objective of collaring the elephants was to monitor their seasonal movements and distribution patterns map their habitats and routes within and outside the reserves provide information to enhance their protection through ranger's patrols and land use planning. The elephant collar is fitted on the neck of an elephant consists of satellite GPS, temperature sensor and a powerful battery (Lithium Ion Batteries) which can run for 3-5 years. The GPS on the collar sends information of the location and activity pattern of the elephant on specified time intervals such as every 20, 30 minutes etc. Such information will be useful in mapping the activity pattern of the elephant as part of its monitoring. This is illustrated in Fig. 2 with one of the co-authors from Tanzania with the GPS collars.



Fig. 2 GPS collar at Ruaha National Park in Tanzania

which are similar in regard to animals  
own right, but, applying these into a single  
in addition, this paper offers a solution to  
in detecting animal behaviour or poaching  
arks cause many extra costs and, certainly  
poaching prevention have added many  
problems including mistakenly attack and issues of human right breaching. Using intelligent  
wireless sensor network tracking and monitoring system will report the poaching incident at the  
time it happens. The proposed sensor system has built in measures to use animal fear behaviours

and horns synchronizations to poaching incident, and shows the location through GPS. Furthermore, this system may assist monitoring normal animal's death, and understanding animal's group behaviours.

## **2.5 An Intelligent Tracking and Monitoring System**

This research paper proposes the use of an intelligent tracking monitoring system. An appropriate endangered animal is chosen, in this case elephants and rhinos and attached with appropriate sensors. The preferred part of the body, tusk and horns of elephant and rhino are attached with sensors which will be synchronized to each other and to the gateway wireless network. The part of the body, horns and tusk must be carefully chosen such that it will not disturb an animal and give wrong results because of unnecessary movements resulting from scaring attached sensors. Also, the position of the sensors must be in such a way that they will also be able to send information to the gateway wireless network.

## **2.6 Proposed System Infrastructure**

The devices essential to the system include the following:

### **2.6.1 Communication Channel**

The best method proposed in this paper is the use of access points as this method is cost effective. Access points are used to collect movement data from sensors attached to elephants (MBS) and send them to a central computer. To succeed these Mobile Network Operators base stations can be used. Also, high voltage poles, tall massive trees and watch towers are possible access points. However, satellite-based systems can also be applied; employing satellite system is fairly complex and costly as it requires a satellite to focus on specific area only such as national parks only.

### **2.6.2 A central Computer System**

This device must be connected with neural network, the device will classify data received continuously from the animal body sensors and GPS via access point and suggest if it is normal fear (harassment) or it is fear caused by a dangerous action like poaching.

### **2.6.3 Sensors Network**

The sensor network comprises with smart sensors attached into the horns and body of the animal. The ZigBee wireless sensors will be used to connect the signals from the synchronized horns to

the collar tag. Portable GSM modem/ ZigBee will be the default gateway from the collar tag, which will send the signal to the sensor nodes access points and then to base station. All the sensors will be powered by small solar panels with Lithium ion battery, which will be attached to the horns and the collar tag. Also, Piezoelectric will be used as the backup charging mechanism in case of the solar power failure.

### 2.6.4 Cellular Smartphone

Mobile application software will be designed for receiving a message about the panic of animals and the location where that panic/harassment is taking place as it has been demonstrated by Bagree *et al.* (2014). It is recommended that the device must be owned by game rangers at work who will be ready to take action whenever they receive a message. However, the information received in the cellular phone must be synchronized with those from a central computer system for reliability (Fig. 3).

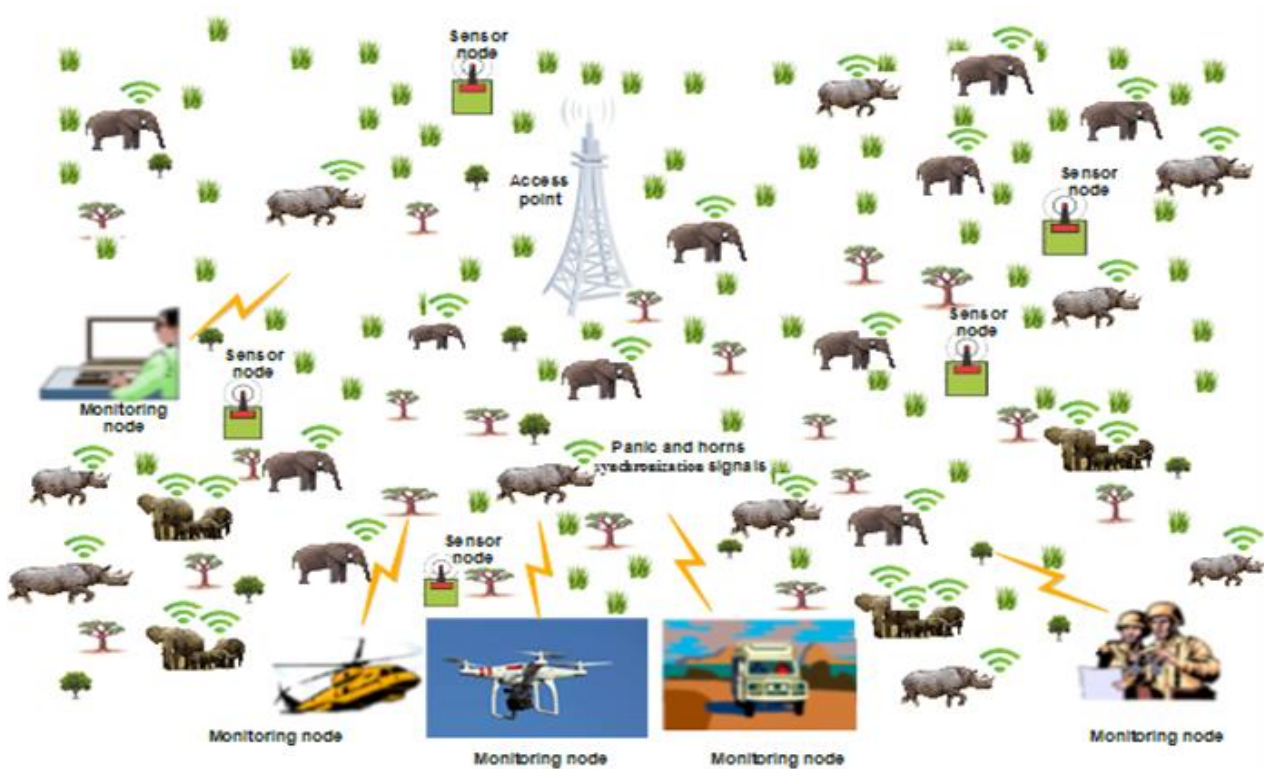

**Figure 3: A Proposed Illustration of an Early Warning System**

### 2.7 System Operation

The system (Fig. 3) works as follows: Access point receives sensors location continuously and sends it to a central computer where it stores it in a database. This computer is fed with a specific artificial intelligent algorithm. A classifier indexed to the database will continuously check the

database to determine any abnormalities on sensors' values. Using artificial intelligent tool, a classifier will attempt to determine whether or not there are abnormalities on animal bodies' parameters, horns line of sight synchronization and voice or sound compared to usual learned behaviour of the animal. If a sudden panic of animals occurs an abrupt change in the graph of a classifier in the central computer occurs, this shows a potential incident and the system responds by first raising an alarm, secondly displaying the current location and time using GPS. Furthermore, a system will send a short message (SMS) to the game rangers and drones through a GSM network to draw their attention on the suspected area. If immediate measures are taken by the game rangers poachers will be easily arrested and poaching will be disregarded in this way.

## **2.8 Discussion**

The proposed anti-poaching intelligent system uses sensors. In order to determine whether to apply this system in the particular parks such as Tanzania National Parks, it may be important to look at some advantages and disadvantages of the system. Among the advantages of the system are: The system is very convenient and can be easily adopted to current anti-poaching systems, the system is cost effective as sensors are cheap and can be integrated to available infrastructure, applying this system will reveal more knowledge on animal behaviour, also the system can be applied for other purposes such as comprehensive animal death. As stated above the system may have some drawbacks such as: It is not easy to capture dangerous animals like elephant and attach them with sensors; hence needs trained personnel. Also, the use of battery brings about many problems such as pollution and extra radiation.

## **2.9 Conclusion and Recommendations**

This research paper presents an intelligent animal tracking and monitoring system, and therefore, it can be applied to any endangered species at a particular time. However, the system does not come to replace the current anti-poaching initiatives, but rather to combine the efforts in order to get rid of poaching prevalence. This system could prevent potentially serious poaching activities occurring in different parts of Africa particularly Tanzania. It is expected that if Tanzania National Parks (TANAPA) employs this sophisticated technology to curb poaching activities will be of great advantage to TANAPA as it is reliable and will reduce the economic burden of investing too much on anti- poaching. At this stage the system is under designing and prototyping. Even though it is beyond this project application of wireless technology and computer vision will dramatically improve the system. Finally, new sensors with improved

capacity and robustness can be applied to the system. It is noticed that the life of important animal species is threatened due to poaching, and if affirmative actions are not enforced, the loss of certain species which will lead to dramatic ecological imbalance may occur. This thesis aims at presenting an alternative way to fight poaching using sophisticated technology which seems to be efficient and cost-effective to employ.



## CHAPTER THREE

### Design and Analysis of Smart Sensing System for Animal Emotions Recognition

#### Abstract

Animal emotion recognition has become an important field for developing intelligent systems for tracking and monitoring plotted animals like rhinos and elephants. In this work, a smart sensing system that detects animal emotions by using information from physiological parameters obtained from sensors attached on animal body has been designed. Heart rate sensor, galvanic skin resistance sensor and body temperature sensor provide the signals which are then amplified and filtered before being processed by the microcontroller and wirelessly transmitted using a GSM modem and ZigBee technologies. Once received, the signals are shown on the display and saved in the database where visually for patterns can be analyzed. In this project, four basic emotion parameters observed. These are happy (excited), sad, angry and neutral (relaxed). The data clustering algorithm used for clustering data into four groups for automatic animal emotion recognition was K-means clustering algorithm. In this research dogs have been used for the pilot study.

---

<sup>2</sup>This chapter is based on: E. Massawe, M. Kisangiri, S. Kaijage and P. Seshaiyer, "Design and analysis of smart sensing system for animal emotions recognition" *International Journal of Computer Applications* (0975 – 8887) Volume 169 – No.11, July 2017

#### 3.1 Introduction

Research on emotion detection is a very challenging arena that targets methods to make effective intelligent sensor network for endangered animal's species that can report poaching incidence before happening. Recent researches have been focused on tracking the animal's positions only by using GPS attached on the animal body. Emotions has a critical role in rational and intelligent behaviours. As a mental state, emotions do not rise voluntarily and they usually go along with physiological changes. Monitoring of such changes can assist in understanding behaviours as they contain data about different kinds of emotions.

As observational methods in animal behaviour researches have always gone hand in hand with the development of new technologies (Meng *et al.*, 2009). In respect to this, we started to customize available sensor node technology and apply it to collect and propagate data from living animals. Currently, we are equipping cows and dogs with standard sensor nodes as a pilot study

and developing a custom sensor suite, adapted to their specific requirements. Each sensor is contained in a module (referred to as sensor board) that performs signal conditioning and basic feature extraction. Thus, sensor nodes are attached to a cow and dog, using a leather harness, fitted with a pocket for the sensing equipment. The long-term goal is to attach, or even implant, the sensor nodes to rhinos and elephants.

This work aims at designing a sensor system capable of identifying animal emotions through measurement of the animal body's physiological parameters by smart sensors. In regard to this, the study will design a sensor-based system which is either invasive (indirectly attached to the animal body) or non-invasive (indirectly attached). This system, being based on sensors, can also be utilized to positively impact the animal's health monitoring system.

### **3.2 Related Works**

Various methods and approaches have been used in the past for detection and evaluation of human emotions. The most common methods used are such as using electroencephalogram (EEG) signals, speech, facial expressions, body gestures, physiological signals and textual information. The EEG signals have been employed for nervous system analysis to give information about different types of emotions. Facial expressions changes' detection is done using cameras and image processing techniques that use an external stimulus which excite specific emotions (Verma & Tiwary, 2013). By monitoring the speech tone, information about the emotions of an individual can be obtained using voice recognition systems. On the other hand, words used in a developed chatting system are the basis of recognition of textual emotion. For the case of emotion recognition, emotion is evaluated by body movements and gestures with regard to specific actions or dances assigned and naturally occurring (Verma & Tiwary, 2013).

In this thesis, an emotion recognition system is designed using physiological signals. These signals are obtained from a heart rate sensor, a skin temperature sensor and a skin conductance sensor and stored for data analysis and feature extraction. The four basic emotions considered in this paper are happy (excited), sad, angry and neutral (relaxed). A number of relevant wildlife tracking projects already exist; however, for the purpose of this study, the Zebra Net project by Juang *et al.* (2002) equipped Zebras with customized sensor nodes can be applied. The animals' location and other related quantities are monitored by GPS. The sensor nodes are recorded when and where zebras met. By using this information, biologists assess the zebras' movement and social interactions (Thiele *et al.*, 2008; Allan *et al.*, 2015). The use of tracking collars is one of the most common methods of monitoring wild animals whereby the GPS is used to record the

animal's exact location and store the readings at pre-set intervals (Wildlife Act, 2014). For the purpose of our study, a dog is used for collaring. Locations are logged and can then be downloaded in various ways, and the older GPS collars are used to store data until the collar was retrieved; similarly, GPS collars allow data to be downloaded remotely. The GPS/GSM collars use GSM cell phone signal to download data. Store-on-board GPS collars can store data which is then downloaded remotely using a handheld Ultra High Frequency (UHF) device. The SAT/GPS collars use global Satellites to transmit the position and other data to a user's server/desktop. The very high frequency (VHF) tracking collar attitudes also known as a pulse collar (Wildlife Act, 2014) can be applied. The VHF transmitters attached to a study animal emit a pulsed radio signal allowing a person to physically locate and observe the animal by homing into the signal using a receiver and directional antenna (Wildlife Act, 2014). The proposed a hybrid network to effectively control movements as it was demonstrated in the work of Guironnet *et al.* (2005).

### **3.3 Cattle and Dog Behaviors**

Cows are known to display subtle behaviors to express their emotions. While these expressions are hard to see, one can carefully observe patterns in their behavior. For instance, the amount of white showing in cow's eyes are related to stress and frustration or even pain (Sandem *et al.*, 2002). Also, it has been observed that calves that are separated from their mothers approached new objects with more reluctance than other calves (Jensen *et al.*, 1998). A Cambridge University study found that young heifers are excited upon discovering they can accomplish something physically such as opening a gate themselves by pressing a button with their noses, but not if the gate opens randomly. Besides intellectual or physical stimuli researchers have also observed that grazing cows often opt to stand near others with whom they are most familiar. However, many dairy farmers choose to separate cows according to productivity and reproductive state. The study suggests that herders may benefit more from allowing cow cliques to remain together (Balcombe, 2015). Similar behaviors have been observed in dogs as well. For example, some dogs are known to show separation-related behavior that may have underlying negative emotional states.

Other studies have suggested that dogs can experience negative emotions in a similar manner to people, including the equivalent of certain chronic and acute psychological conditions such as depression. Some researchers also have observed dogs showing jealousy against other dogs that may be rewarded more. Researchers also believe that dogs show empathy which is feeling what others feel. Empathy is the ability to not only detect what others feel but also to experience that

emotion yourself (Bristol, 2010). The Dr. Peter Pongracz from Eotvos Lorand University, Budapest, and colleagues have produced evidence that dog barks contain information that people can understand. Their research suggests that even people who have never owned a dog can recognize the emotional 'meaning' of barks produced in various situations, such as when playing, left alone and confronted by a stranger (Reporter, 2008).

### **3.4 System Design**

The designed smart system consists of both receiver and transmitter sections. The transmitter section consists of physiological sensors, signal conditioning circuit, an Arduino Mega 2560 R3 and ZigBee module. A receiver section consists of ZigBee coordinator and a computer for data storage. The data from the smart system is wirelessly transmitted to a computer where it is displayed and stored. The commercial, off-the-shelf sensors, basic processing (8-bit, 7 MHz) and radio communication (900 MHz) were used as contended by Crossbow Technology (2006). Sensors are attached to the cattle/dog using a leather harness, onto which a bag (containing the sensor) is fastened with Velcro. The designed leather harness consists of a leather band, wrapped around the rib cage, and a stiff wire loop around the neck to keep it from sagging off to the side. In order to reduce processing and memory complexity we have developed smart sensing modules to perform in hardware as much of the signal conditioning and feature extraction as possible. At present, we have two functioning sensor boards: One for heart rate analysis and the other for body temperature analysis (Thiele *et al.*, 2008).

### **3.5 Heart Rate Sensor**

The most common heart rate inconsistency at rest can be due to serious heart problems, respiratory problems and emotional imbalance i.e. stress, panic attacks, anxiety and depression. In this research the interest is to find relationship between heart rate and emotions. The PSL-iECG2 (Fig. 4) is a small 2-channel ECG module that outputs ECG wave forms and heart beats. The DC 5V input power can be used to power Arduino board without any other power supply which is very convenient. Amplification is a 750 V/V. The notch filter can be adjusted to 50 Hz or 60 Hz by the notch filter selectable switch. The module outputs a high-quality ECG signal by applying the low noise and optimal filter design. The PSL-iECG2 guarantees electrical safety through isolation power and signal during measuring. For the high quality signal input the premium lead cable with shield is provided, and the cable adopts a stereo jack to connect simply (PhysioLab, 2016).

In order to process the ECG features; first subtract the global mean value of the raw signal that might be shifted up or downwards by the recording device. The signal is filtered with a low pass filter with  $f_c=90\text{ Hz}$  to remove high frequency noise, a very sharp high pass  $f_c=0.5\text{ Hz}$  to eliminate low frequency drifts that occur when the subject is moving and then a notch filter at  $f_n=50\text{ Hz}$  that removes influences of the power line. The detection of ECG graphical deflections complexes (QRS) was done through following Algorithm (Rangayyan & Reddy, 2002). This is a derivative based method for detecting QRS complexes of the ECG signal consisting of a weighted sum of the smoothed first derivative and the approximated second derivative (Haag *et al.*, 2004):

$$y(n) = (a \times x(n) - x(n - 2)) + (b \times x(n) - x(n) - x(n - 2) + x(n - 4)) \quad (1)$$

where  $x(n)$  is the input signal,  $a$  and  $b$  are the weight parameters for the balance between the smoothed three-point first derivative and the approximated second derivative and  $y(n)$  is the output of this stage. The  $a$  and  $b$  are set to 1.3 and 1.1 according to Rangayyan and Reddy (2002). A further smoothing of the result is obtained by the introduction of an  $M$ -point moving average filter such that:

$$y_{fit} = \frac{1}{M} \sum_{j=0}^{M-1} y(n - j) \quad (2)$$

According to Haag *et al.* (2004), the resulting signal is scanned with an adaptive threshold that is defined by (3):

$$thres(n) = \frac{\max[n-k, n+k] - \min[n-k, n+k]}{\alpha} \quad (3)$$

The result is a list of samples each indicating the onset of a single QRS complex. This list is used to calculate a set of different features like heart rate (HR), heart rate variability (HRV) and the inter beat interval (IBI) between consecutive heart beats. The HRV for example is influenced by the sympathetic and parasympathetic vagus nerve and therefore a good indicator for the temporary dominance of one of them. The HR is calculated simply by using the difference between two consecutives detected QRS complexes ( $t_{HB}$ ):

$$HR(n) = \frac{1}{60} \cdot \frac{t_{HB(n)} - t_{HB(n-1)}}{fs} \quad (4)$$

However, in order to make it more stable against artifacts and irregularities of the heart function the logic was introduced that calculates the mean duration of the previous IBIs and checks if the next heart beat occurs within a range of  $\pm 15\%$ . If this constraint is violated, then an out of range increase of the heart rate and correct the signal was assumed by introducing a beat at the expected position. This prevents missed QRS complexes or anomalies from influencing the HR. The HR itself is used as a feature as well as the previously mentioned common features derived from it (Haag *et al.*, 2004).

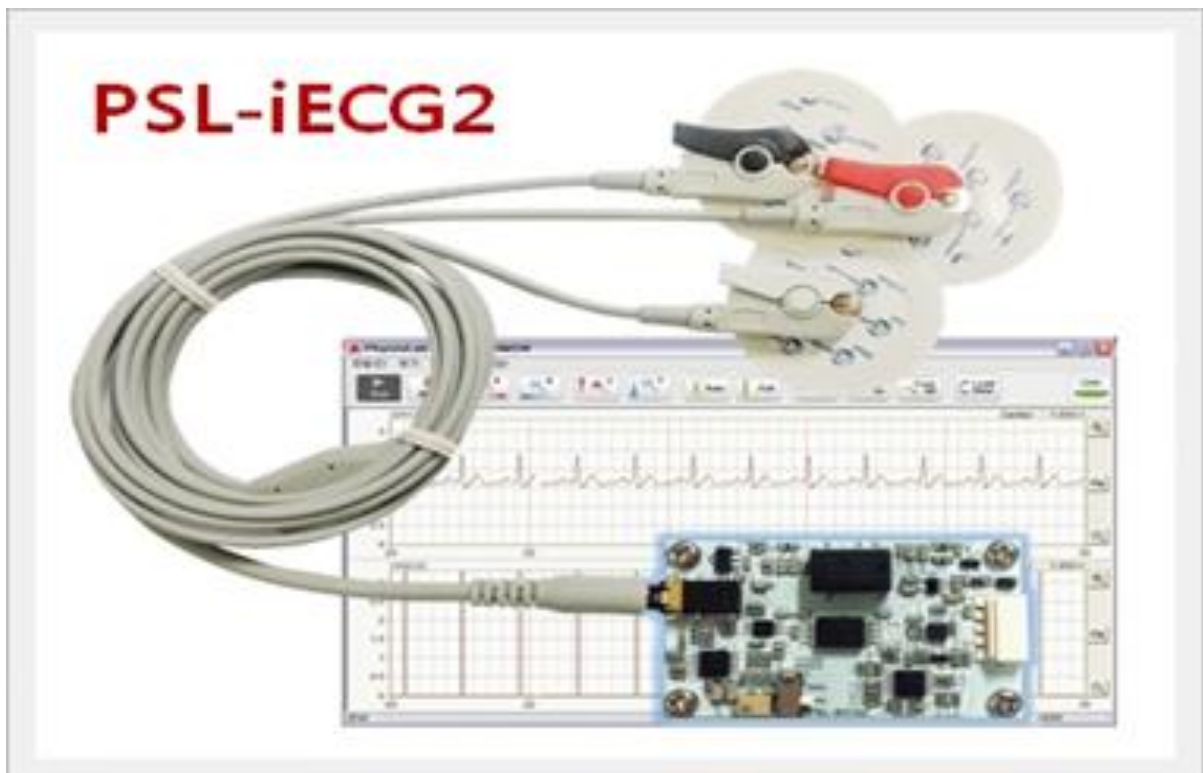

**Figure 4: The PSL-iECG2 (Mini-size 2ch ECG Sensor Module with Isolation)**

### **3.6 Body Temperature Sensor**

The LM35 is used as a temperature sensor because of its accuracy integrated-circuit temperature sensors with an output voltage that is linearly proportional to the Centigrade temperature (Poonam & Mulge, 2013). Thus, the LM35 has benefit over the linear temperature sensors that are calibrated in Kelvin, as the user is not required to subtract a large constant voltage from the output to obtain a convenient Centigrade scaling (Poonam & Mulge, 2013). The LM35 does not require any external calibration or trimming to provide the typical accuracies of  $\pm 1/4$  °C at the room temperature and  $\pm 3/4$  °C cover a full  $-55$  °C to  $+150$  °C temperature range (Texas Instruments Incorporation, 2013). It is further asserted that the low output impedance, linear

output and precise inherent calibration of the LM35 sensor make interfacing to readout or control circuitry especially easy, and the device is used with single power supplies, or with plus and minus supplies. As the LM35 sensor draws only 60µA from the supply, it has very low self-heating of less than 0.1 °C in the still air (Texas Instruments Incorporation, 2013). The LM35 is rated to operate over a -55 °C to +150 °C temperature range, while the LM35C is rated for a -40 °C to +110 °C range (-10 °C with improved accuracy). There are a number of devices available for monitoring or observing body temperature but for the purpose of this research which was to look for a low-cost, compact, reliable and accurate temperature sensor that is capable of monitoring the body temperature with ease and comfort (Texas Instruments Incorporation, 2013).

As stated earlier, the output from the temperature sensor is an analog voltage. This output signal from the sensor is used as the input for the microcontroller through the analog port pin. The microcontroller is programmed to perform the required processing and conversion from a voltage value into a temperature value (Texas Instruments Incorporation, 2013); and the relationship between the voltage value and the temperature value is calculated by the following equation:

$$T(^{\circ}\text{C}) = \frac{V_{out} - v_{OS}}{\Delta V / \Delta T} \tag{5}$$

Where  
 $v_{OS} = Ds \text{ offset, } 509\text{mV}$   
 $\Delta V / \Delta T = \text{Typical output gain, } +6.45\text{mV}/^{\circ}\text{C}$

A microcontroller is inexpensive, flexible and self-sufficient design permit in it to command almost any modern task that employs some form of embedded systems; from cars to refrigerators to handheld devices, microcontrollers play a dominant role in the development of many different products for many different companies (Texas Instruments Incorporation, 2013).

### 3.7 Microcontroller Overview

In this research, the Microcontroller used is PIC XMEGA256A3. The PIC XMEGA256A3 includes brownout detector, a 16bit CPU, 16-bit timer, 16-bit Sigma Delta Analog-to-Digital converter, Watchdog timer, USI module supporting SPI and I2C serial communication standards, and five low power modes drawing as little as 0.1 µA standby current (Texas Instruments Incorporation, 2013).

### **3.8 Communication**

The smart system is designed to communicate with the computer wirelessly as well as using an RS232-USB. The wireless communication is achieved by using ZigBee technology suitable for low rate data and secure networking (Fernandez *et al.*, 2010). It has been broadly used for monitoring applications. It can transmit up to a range of 40m. In this research we used XBee Series 2 OEM RF modules which operate within the ZigBee protocol and uses 2.4 GHz frequency band. It requires a supply voltage of 3 V which is provided by the microcontroller and consumes power as low as 296 mA.

### **3.9 Circuit Simulation Results**

The simulation of the circuit was done on Proteus Professional v 8.0 software package. The software of the system is written in the embedded C language. Figure 5 shows the simulation schematic of the system. The simulated system consists of the following components; microcontroller, body temperature sensor, heart rate monitor sensor, pulse generator, GSP, horns synchronization sensor and virtual terminals.



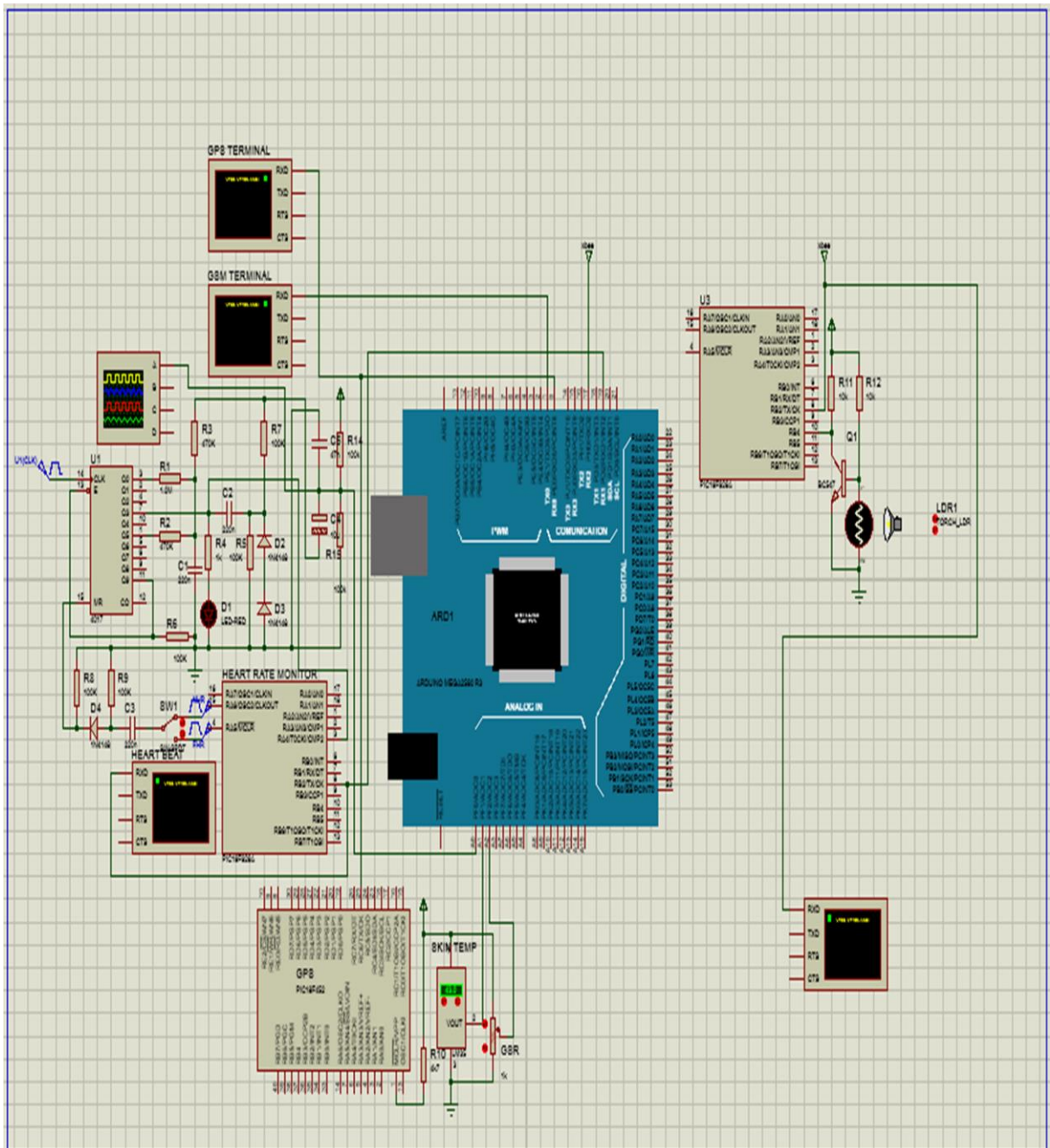
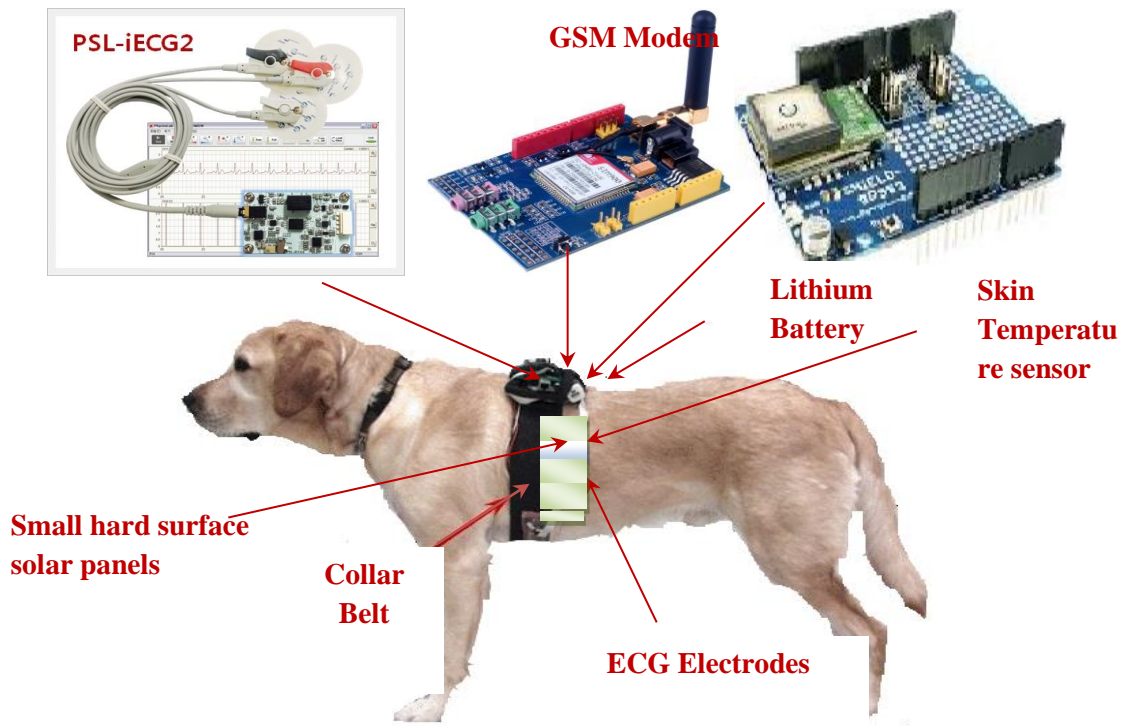

**Figure 5: Proteus Circuit Simulation Schematic for Anti-poaching System**

### 3.10 Circuit Simulation Output

The circuit simulation output is as shown on Fig. 6. This is the output notification messages from the system. The message displays the heart beat rates, body temperature and status of the horns synchronizations. It also shows response signal sent to drone, mobile phone and data base.





**Figure 7: System Model with the Sensors and Electrodes**



**Figure 8: Model of the Solar Powered Collar Belt**

The signal from the sensors are processed by PIC XMEGA256A3 microcontroller and sent wirelessly by the ZigBee transmitter which is received at the other end by the ZigBee receiver. The receiver is connected to the computer via the USB port. The data after being received is displayed using LabView and is stored in the database. The next step was to collect data from different dogs and observes the changes. This is explained in the results section.



### 3.12 Data Collection

Pilot study data was collected on dog using prototyped collar belt (Fig. 9). Collected data was coded using MATLAB. Figure 10 shows the main effect for sensor variables as well output of different emotional intelligence test on dogs. The conducted research demonstrated that dogs have different emotional expressions as that of humans (e.g. angry (Panic), happy faces and neutral (normal) faces). The evidence for recognizing an emotional expression is stronger if dogs' behavior alters in a preliminary predicted and meaningful way. Dog heart beats increase more when the dog is subjected to panic due to different situations that are not normal to it.



**Figure 9: A prototype Collar Belt**

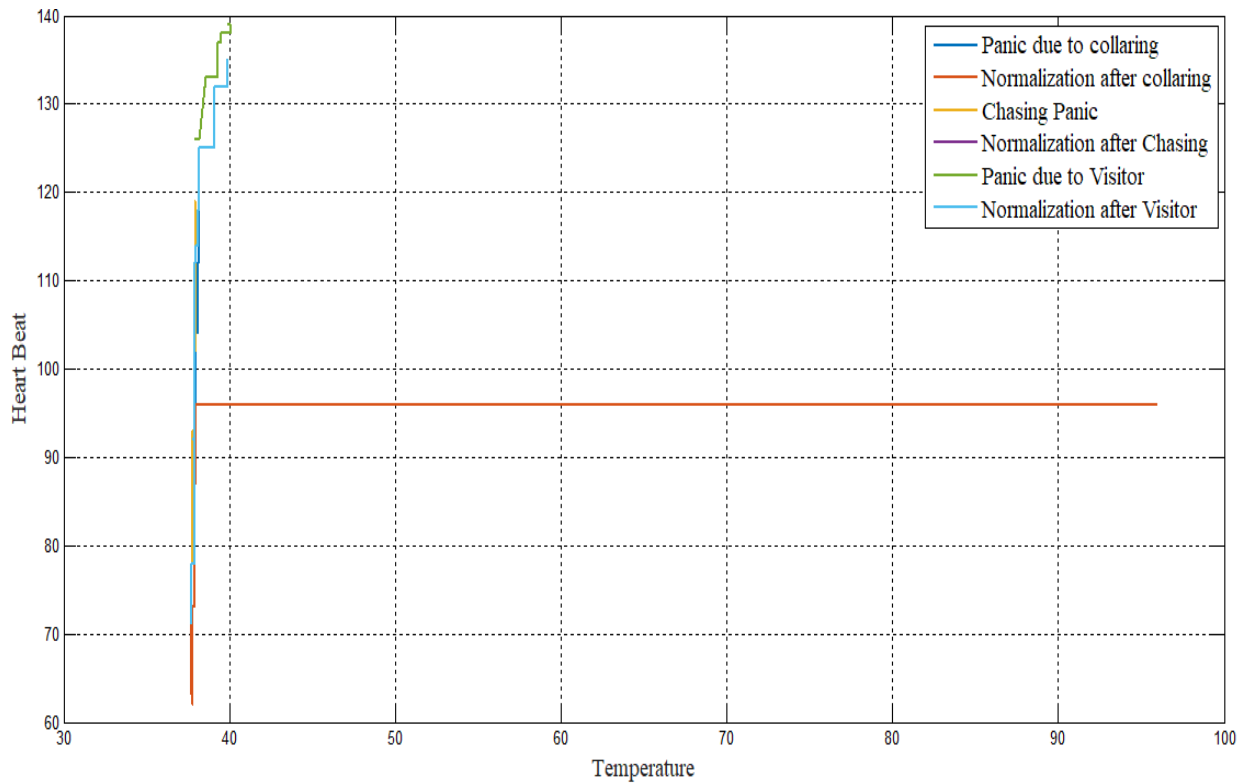

**Figure 10: Panic and Normalization of Dog’s Heartbeat and Temperature**

### 3.13 Results and Discussion

Once the consistency of the sensors was tested, we started gathering data from dogs as pilot studies for our project. This information was stored in order to help finding obvious visual patterns and also using it for feature extraction. The results of heart beat, body temperature data are collected from subjects in happy (excited), sad, relaxed (neutral) and angry states. The results proved that different emotions have an effect on the physiological signals which can be visualized by continuous monitoring. The heart rate variability was the dominant signals in this case. The heart rate values showed that, the higher the relaxed state, the lower the heart rate values get and vice versa, which proves that the heart rate values are directly related to the level of arousal.

### 3.14 Conclusion and Recommendations

In this research, we have developed a real-time emotion recognition system based on data provided by physiological sensors. Physiological sensors were found to be the best approach to recognize emotional changes, as they provided information about changes that take place physiologically and are out of the animal’s control. The sensors have been integrated and placed

on the inner surface of the collar belt, for collecting data from the animal body. This design enabled an easy and comfortable data monitoring system.

For future improvement and development of the system, the use of additional physiological sensors such as Voice control sensor, pressure sensor and respiration sensors are required. In order to get more information from the data other clustering methods should be looked into which can help improving emotion recognition rate. The system once fully developed will be capable of extracting basic emotions i.e. happy, sad, angry and neutral from the physiological signals. It can be integrated with the drone, which will help on immediate response to poaching incidence.

## CHAPTER FOUR

### Computational Models Analysis of Wildlife Tracking System for Optimality: A Case Study of Ngorongoro Conservancy

#### Abstract

The growing interest in applications of wireless sensor networks (WSNs) in different environments has made it important to understand and be able to predict the impact of attenuation on coverage and signal quality. As wireless communication moves from long to short ranges with considerably lower antenna heights, the need to analyze vegetation attenuation, atmospheric attenuation and terrain attenuation on coverage and quality of wireless services has similarly become very important. This paper focuses on attenuation measurements for frequencies in the range 900 MHz–1800 MHz in Ngorongoro Conservation Area to evaluate attenuation models for application in wireless sensor network planning and deployment in wildlife tracking system. Although several models have been proposed and evaluated for specific frequencies, results show that these models do not perform well when applied to different vegetation types or at different frequencies. In this paper a computational model for radio wave propagation is presented.

#### 4.1 Introduction

Past studies have relied on wireless networks for creating wildlife tracking systems and every time it has been evident that it is a new adventure because of variability of interference surfacing in the course of design (Vieira, 2003). Wireless interference is an important consideration when planning any wireless network. Unfortunately, it is an inevitable bottleneck, but the trick is to minimize the levels of interference. Wireless communications typically are based on radio frequency signals that require a clear and unobstructed transmission path; and so, the goal during design is to get as close to such an ideal transmission path as possible.

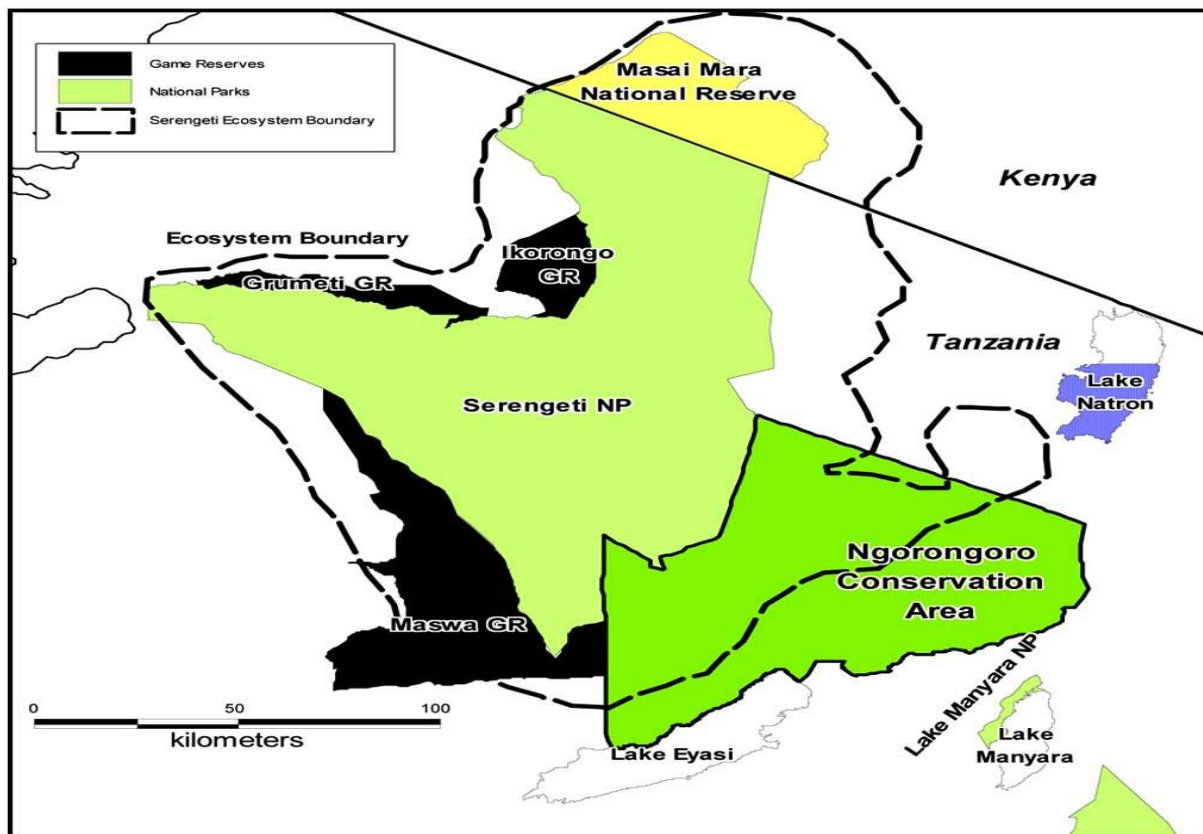

**Figure 11: Ngorongoro Conservation Area Map (NCA, 2014)**

Wildlife tracking solution in Ngorongoro Conservation Area (Fig. 11) is a unique engineering, design and technology challenge. A number of blocks are involved and all need to be considered for an optimal tracking network particularly in relation to signal transmission and reception. Ngorongoro environment is characterized by varied vegetation from grasses, sparse trees to dense forests, woodlands, rivers, swamps, lakes, hills, mountains and many more forming a habitat of endangered animals like elephants and rhinos. Each one of those features presents a serious network engineering bottleneck. However, the focus of the study is directed towards three areas: vegetation, atmospheric conditions and terrain.

In addition, Ngorongoro is flooded with wildlife at some point during the year as part of Serengeti-Mara ecosystem. Animals enjoy their day in muddy areas, hiding under shadowy trees and tall grasses, swimming in pools and rivers; and as if it is not enough Ngorongoro can be continuously humid with intermittent rains embraced by dense forests. All those elements demand plausible and well tested signaling and hybrid network architecture for redundancy which in turn render desired reliability of transmissions (SafariBookings, 2013).



## 4.2 Proposed Tracking System

The proposed tracking system (Fig. 12) is composed of three main parts: Wireless sensor network (WSN), GPS and cellular component. The WSN forms the fundamental part for tracking comprising of sensor nodes which are tracking animals wearing collars. The sensor nodes are collars with in-built sensors with GPS and GSM capabilities to enable collection of wildlife locality and health related data (Allan *et al.*, 2013). The cellular part is essential for monitoring purposes. The cellular part in the architecture (Fig. 13) includes GSM modem in collars, signal boosters or repeaters and tower(s).

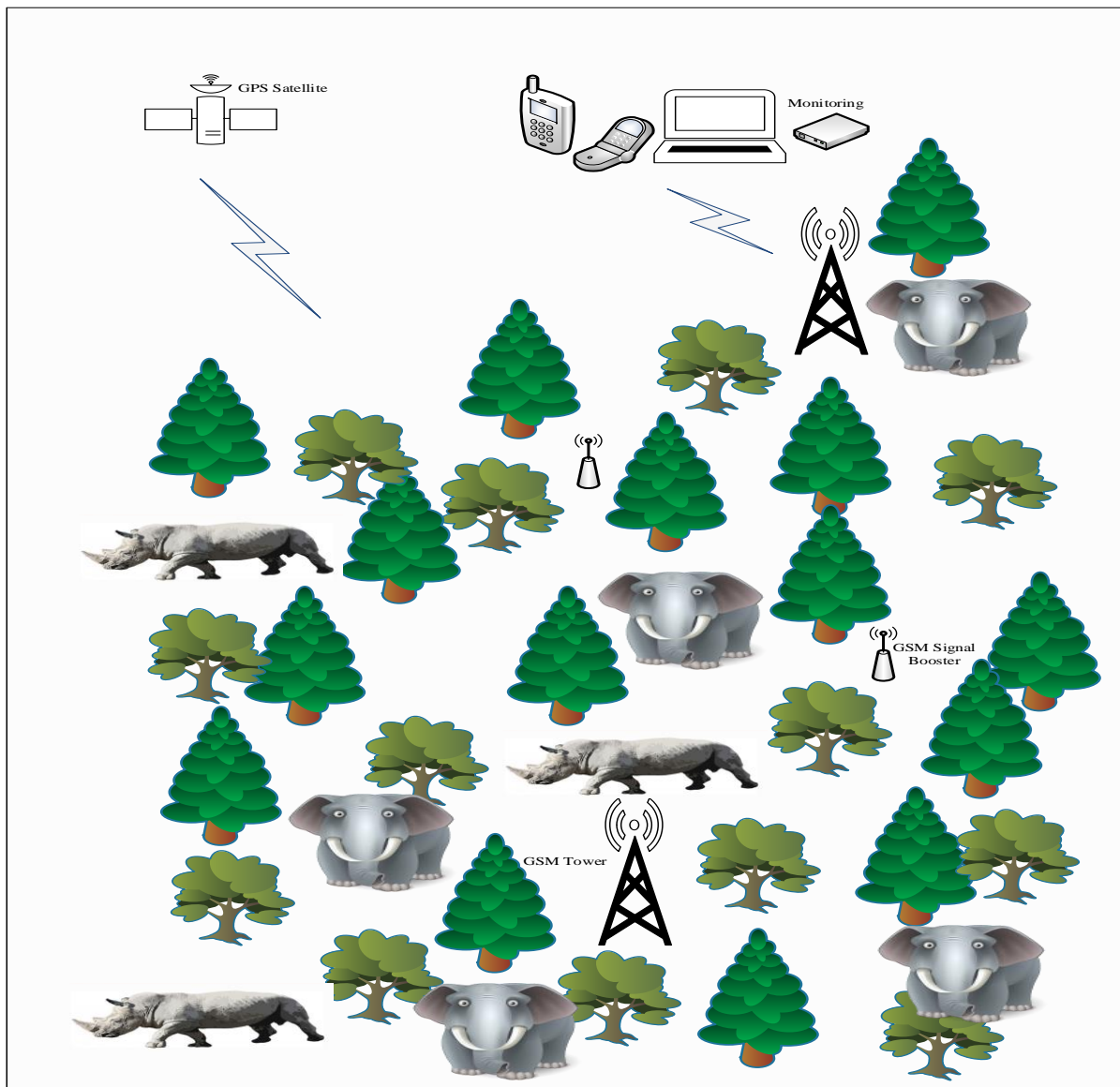

**Figure 12: Proposed Wildlife Tracking System Scope**

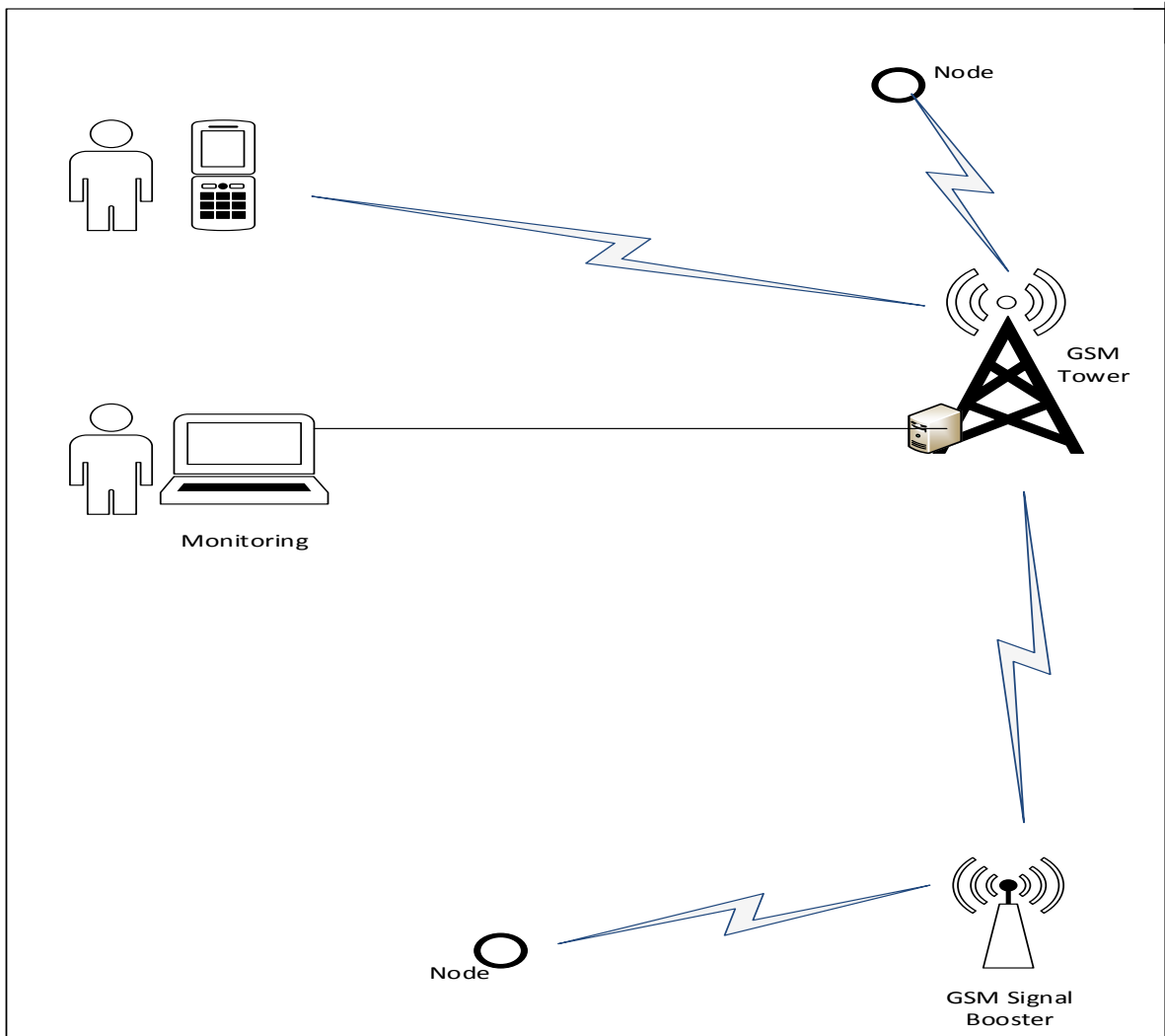

**Figure 13: Cellular Part of Tracking System**

#### 4.2.1 Wireless Sensor Networks

Wireless sensor networks are networks of compact micro-sensors with wireless communication capability (Srivastava *et al.*, 2019). These small devices are relatively cheap with the potential to be disseminated in large quantities. Emerging applications of data gathering range from the environmental to the military. As autonomous devices can provide pervasive distributed and collaborative network of computer nodes; architectural challenges are posed for designers such as computational power, energy consumption, energy sources, communication channels and sensing capabilities. Embedded Systems provide the computational platform for hardware and software components to interact with the environment and other nodes (Vieira, 2003).

#### 4.2.2 Global Positioning System

The US Air Force (USAF) under the guidance of United States Government manages a space-based radio navigation system known as ‘Global Positioning System’ (GPS). The original aim for developing GPS was military force enhancement (USA Government, 2014). These applications included tracking, navigation, positioning and timing-based services, in various field such as environment, aviation, agriculture, marine, public safety and disaster relief, space explores, survey mapping etc. Utilizing the numerous advantages of SPS (USA Government, 2014) such as Google map interfacing with GPS and CDS. These implementations are very useful in cases where it is required to trace a thief or to intrude someone’s privacy (Mulla *et al.*, 2015). The system incorporates the advantages of a synchronized GPS and Global System for Mobile Communications (GSM) system for real time positioning, implementing a smart and internet-supported management software (Mulla *et al.*, 2015).

Generally, GPS satellites orbit around the earth in Medium Earth orbit (MEO) with an approximate altitude of 20 200 Km (Mulla *et al.*, 2015). In order to extend navigation support to users all over the world, every satellite engenders and transmits a navigation message, containing data that periodically gets updated from the control segment (Mulla *et al.*, 2015). A 1.023 MHz Pseudo Random Noise (PRN) Coarse/Acquisition (C/A) code sequence is added to this data. With the help of L-Band carrier frequency signal (L1) of 1575.42 MHz, the satellite modulates the resulting code sequence to create a spread spectrum ranging signal (Gray, 2014). The GPS control segment comprises of a worldwide arrangement of ground amenities that assist in tracking the GPS satellites in the constellation, supervise their communication, execute analysis, and launch guidelines and orders, that facilitate the navigation services (USA Government, 2014).

In order to track an object accurately on the earth, a minimum of 3 satellites are required (Mulla *et al.*, 2015). Each satellite broadcasts two signals; one at frequency L1 (1575.42 MHz) and other at frequency L2 (1227.6MHz). A unique satellite code known as the Course/Acquisition code is used to differentiate between the satellites (Mulla *et al.*, 2015). This C/A code is of 1023bits, which modulates L1 signal every 1ms at 1.023 MHz. Assimilating the process, the satellite gathers a 1000 Hz data and transmits it towards the receiver on the earth. This is known as the ‘navigation message’ that is required by the receiver on earth to resolve the geographic position of the object. The contents of this navigation message sent at 50 bps, by each satellite are; “this is satellite ‘X’ reporting, and my location is ‘Y’, sending the information at time ‘Z’. Along with

this data, each satellite transmits some orbital parameters known as ephemeris and almanac data (Mulla *et al.*, 2015).

After receiving the navigation message, the receiver has to perform decoding action in order to extract information. Data is available from the five super-frame structures. But for making sense out of this data, the receiver requires certain algorithms. For determining the precise location of an object on earth, the receiver needs to perform the following as demonstrated in the work of Mulla *et al.* (2015):

- (i) Determining Satellite position in the constellation using Ephemeris data.
- (ii) Correcting the code phase time sent by the satellite.
- (iii) Interpreting User Range Accuracy (URA) parameter.
- (iv) Implementation of a Parity Technique used by GPS, to allow the receiver to detect demodulation error, if any.
- (v) Rectifying Ionospheric propagation delay using a model.
- (vi) Using Almanac data, satellite configuration Information.

In this study attention is directed towards optimality of the GPS receiver considering the fact that it is deployed in a harsh environment with various factors affecting signal transmissions, between the receiver and respective satellites, necessary for determining the intended location.

#### **4.2.3 Global System for Mobile Communication**

Global System for Mobile communication is a digital mobile telephony system that is widely used in Europe and other parts of the world. The idea of GSM was developed at Bell Laboratories in 1970. It is a widely used mobile communication system in the world. The GSM uses a variation of time division multiple access (TDMA) and is the most widely used of the three digital wireless telephony technologies (TDMA, GSM and CDMA). The GSM digitizes and compresses data, then sends it down a channel with two other streams of user data, each in its own time slot. It operates at either the 900 MHz or 1800 MHz frequency band. A GSM network consists of the following components:

**(i) A Mobile Station**

It is the mobile phone which consists of the transceiver, the display and the processor and is controlled by a SIM card operating over the network. In this case, there is a mobile phone for forwarding real-time tracking information and collar with GSM modem attached to the animal which receives all tracking information from sensors and GPS receiving component. Both are treated as mobile stations.

**(ii) Base Station Subsystem**

It acts as an interface between the mobile station and the network subsystem. It consists of the Base Transceiver Station which contains the radio transceivers and handles the protocols for communication with mobiles. It also consists of the Base Station Controller which controls the Base Transceiver station and acts as an interface between the mobile station and mobile switching centre.

**(iii) Network Subsystem**

It provides the basic network connection to the mobile stations. The basic part of the Network Subsystem is the Mobile Service Switching Centre which provides access to different networks like ISDN, PSTN etc. It also consists of the Home Location Register and the Visitor Location Register which provides the call routing and roaming capabilities of GSM. It also contains the Equipment Identity Register which maintains an account of all the mobile equipment wherein each mobile is identified by its own IMEI number. The IMEI stands for International Mobile Equipment Identity.

### **4.3 Ngorongoro Conservation Environment**

To objectively address the environmental challenges posed on the tracking system, it is paramount to elucidate further on the characteristics of NCA and behaviors of rhinos and elephants as they enjoy inhabiting the environment. Particularly the goal is on movements of those animals within the park and areas where they commonly stay or go to; and the atmospheric, terrain and vegetation characteristics of the conservation. Ultimately, the question of the extent of impact on tracking system signals depends on the nature of environment where the animals spend their time during the day or night.

### 4.3.1 Elephants and Rhinos Movements

Elephants and rhinos are heavy animals thus rarely found on highlands or slopes; they spend most of their time in lowland areas.

#### (i) Elephants

The NCA is within the Tanganyet corridor (Fig. 14) by World Elephant Centre (2008), and stretching for nearly 20 km, the Tanganyet corridor links the Natron and West Kili regions extending from the Ngasurai plains in the east to the base of the Kiserian-Mriatata Ridge in the west. In West Kili, the corridor begins as many elephant pathways in a broad 10 km-wide swaths extending west out of the Oltupai Thicket in West Kilimanjaro (Kikoti, 2009). Within 1 km of the Arusha-Namanga Road, the corridor narrows to 3 km wide and the multiple paths coalesce into a single trail crossing the road. It is within this 3 km where elephants use regularly to cross the road. The corridor gradually expands in width west of the roadway to about 6 km at Telecom hill. At this hill, one pathway leads northwest towards Oldonyo-Ndabashi hill and another continues westward to the Kiserian-Mriatata ridge (Kikoti, 2009). The northward path is typically used during the dry season, providing access to artificial water sources used for livestock, with the elephants continuing onto the Kiserian plateau (Kikoti, 2017). According to World Elephant Centre (2008) during the wet season, this pathway is avoided due to human settlements, and elephants continue westward to the ridge and access the plateau from the south (Hoare, 1996; Hamilton *et al.*, 2005; Guldemon & Van Aarde, 2007). The Kiserian-Mriatata ridge and Kiserian plateau provide extensive *Acacia* spp. woodlands, scrublands and grasslands and there is minimal human activity in these areas (Kikoti, 2017).

Also in 1978, the upper Kitete/Selela corridor (Fig. 15) was assigned an NCAA nature reserve (i.e. under the jurisdiction of the Ngorongoro Conservation Authority) with the intention to maintain a route for wild animal movements from the Northern Highland Forest (northern highlands) to the lowlands below the rift escarpment (Tanzania Wildlife Research Institute [TAWIRI], 2009). The Selela corridor extends from the lowlands, particularly the Selela groundwater forest to Lake Manyara National Park. Therefore, the upper Kitete/Selela corridor (2 km wide and 10 km long) is a key feature along the Great Rift Valley that connects Ngorongoro Conservation Area and the Lake Manyara National Park (TAWIRI, 2009).

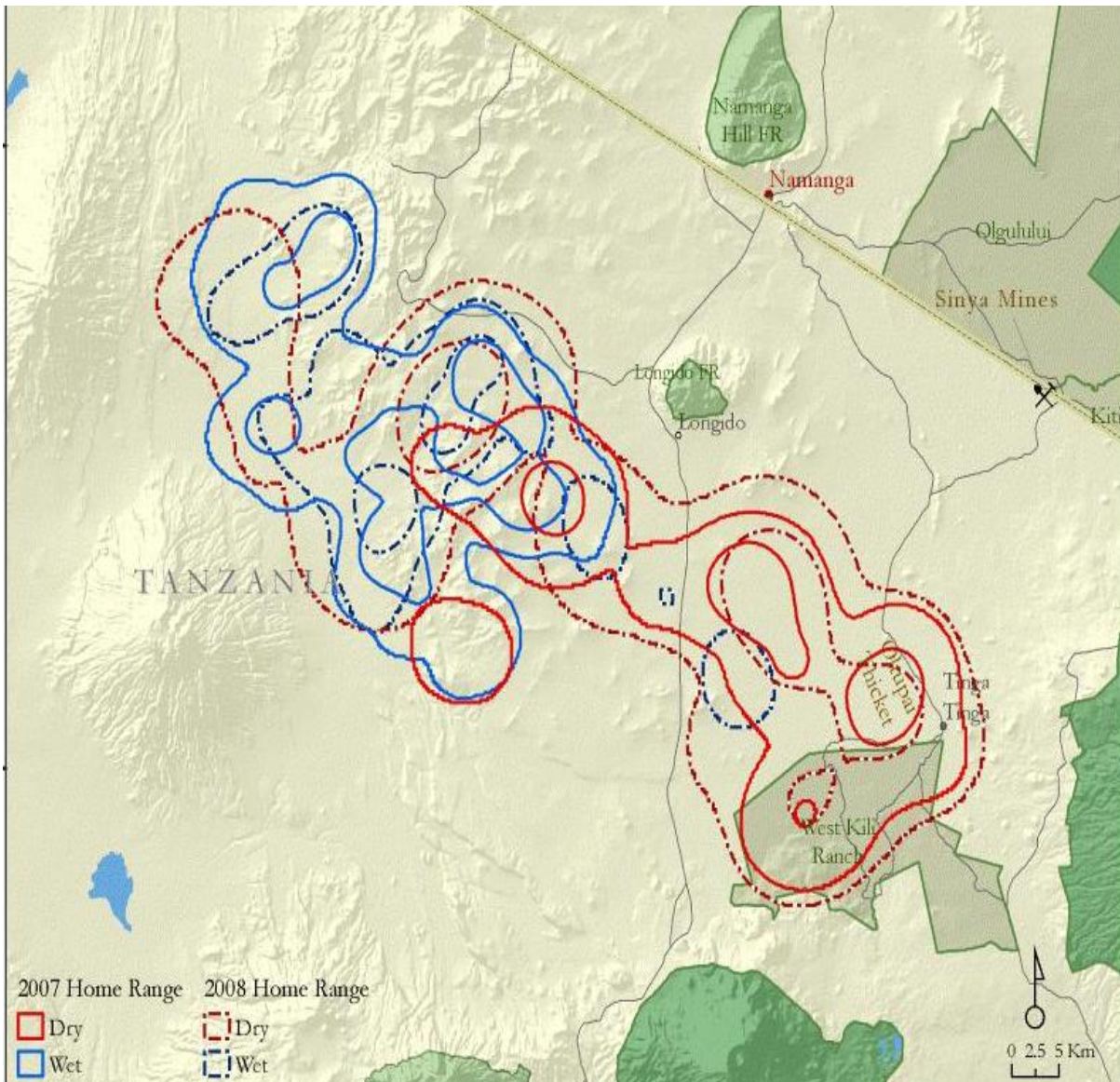

**Figure14: Tanganyet Corridor; A Corridor Identified using Satellite by World Elephant Centre (2008)**



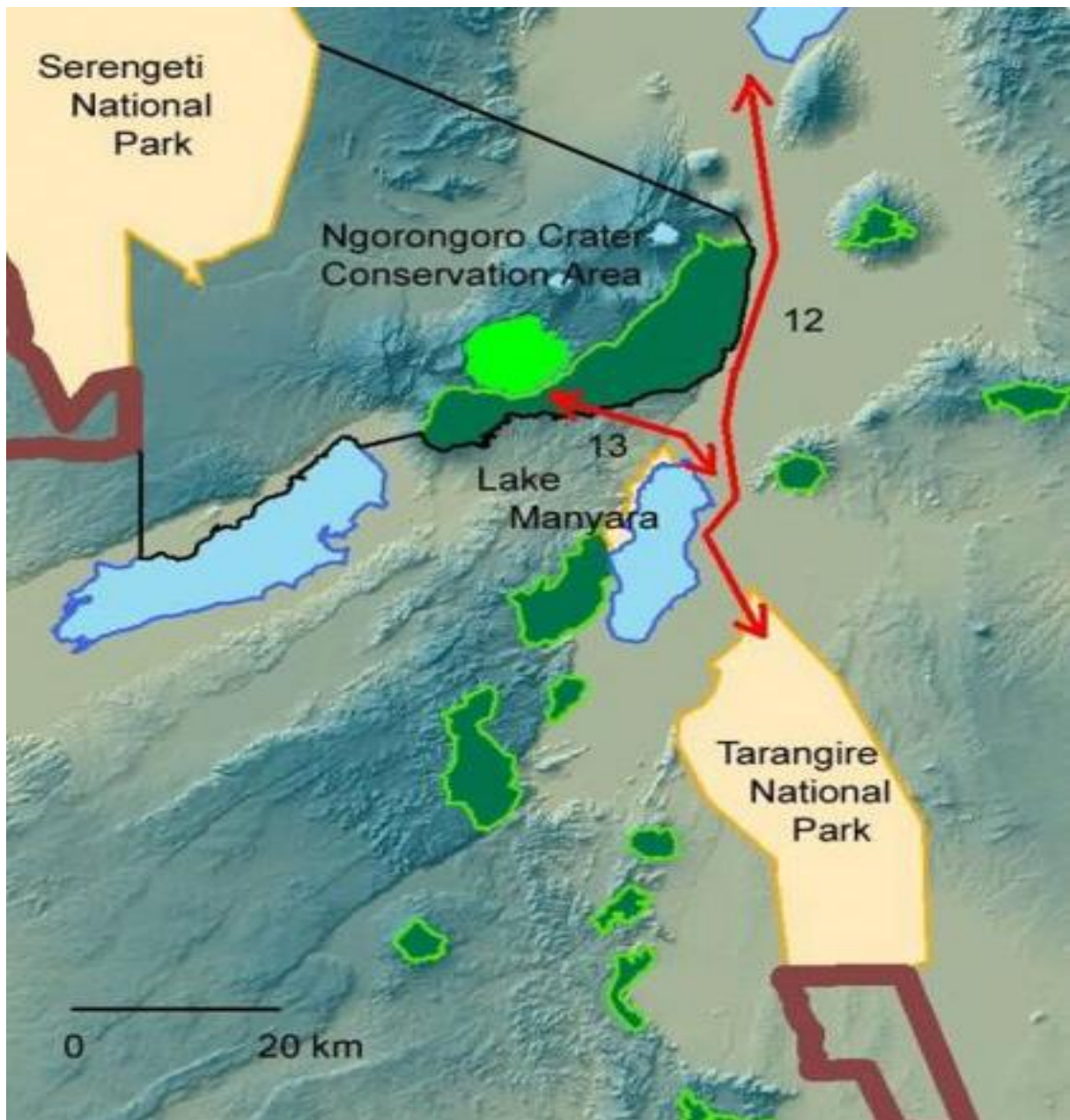

**Figure 15: Upper Kitete/Selela Corridor (TAWIRI, 2009)**

**(ii) Rhinos**

Ngorongoro Conservation Area (NCA) is vital especially for black rhinos conservation because it is one of the only two ecosystems in Tanzania that host native black rhino populations (Makacha *et al.*, 1982; Sinclair, 1995; Gadiye *et al.*, 2016). During the dry period, rhinos are mainly concentrated in the crater slopes dominated by shrubby vegetation, swamps and along riverine areas of the crater (Gadiye, 2016). The distribution of rhinos (Fig. 16) in the crater is influenced greatly by forage items as proxy of seasonal variation; and during wet season there is more herbage material mostly preferred by black rhinos in the crater floor as most rhinos are



sighted in these sampling areas. However, during dry sampling period, most rhinos are sighted in the crater slopes and crater rims. These areas are dominated by perennial shrubs and thickets that are alternative forage items of rhinos when succulent forbs are unavailable (Gadiye, 2016).

On the crater floors, rhinos are sighted only in areas with water sources such as Mandusi swamps, Gorikor swamps and Ngoitok-tok springs. Most spatial distributions during dry season were in forest and shrubland especially Lerai forest. However, large herds of rhinos are more common in wet season too in Lerai forest as it is rich in forage herbaceous and preferred shrubs and trees such as *Acacia xanthophloea* (Gadiye, 2016).

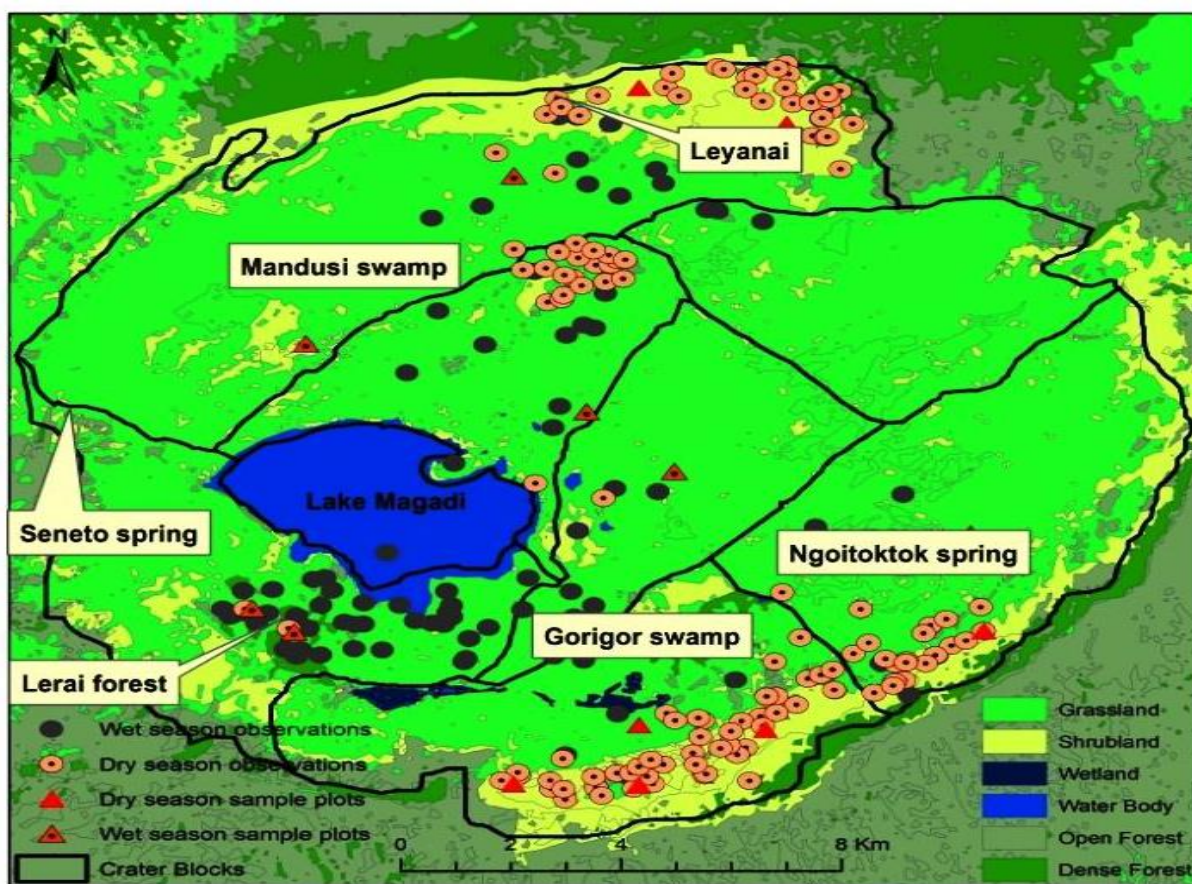

**Figure 16: Rhino Distribution Across Crater during Wet and Dry Seasons (Gadiye, 2016)**

Several habitats frequented by rhino have changed in structure and become less suitable for rhinos (Frankfurt Zoological Society, 2003); these include: (a) The Lerai Forest where trees and understorey have died back; (b) the Gorigor and Mandusi Swamps which appear to have decreased in area and lost much of their leguminous shrub cover possibly due to increased herbivore pressure; (c) the slopes of the Crater where non-palatable bushes (*Lippia*, *Lantana* and *Clausena* species) have encroached into prime rhino habitat that previously comprised short *Acacia lahai* and leguminous shrubs/forbs; and (d) grasslands where there has been an apparent

decline in palatable forbs and an increase in “tall” unpalatable grasses over large areas of the Crater floor. Availability of browse may also have decreased due to (a) the decrease in mean annual rainfall (~950 to ~800 mm over the period 1963-2000 at the NCA HQ); and (b) the increase in the other ungulates particularly the buffalo population as per African Wildlife Foundation (2003), Frankfurt Zoological Society (2003) and NCAA (2003); and Brett (2001), Landman *et al.* (2013), Ganqa *et al.* (2005), and Van Lieverloo *et al.* (2009) concluded that rhino groups adjusted habitat usage for browsing according to season.

#### **4.3.2 Vegetation Cover**

The variations in climate, landforms and altitude within the NCA have resulted in several overlapping ecosystems and distinct habitats. Within Tanzania the area is important for retaining uncultivated lowland vegetation, for the arid and semi-arid plant communities below 1300 m, for its abundant short grass grazing and for the water catchment highland forests (United Nations Environment Programme [UNEP], 2011). Scrub heath, montane long grasslands, high open moorland and the remains of dense evergreen montane forests cover the steep slopes. Highland trees include peacock flower *Albizzia gummifera*, yellow wood *Podocarpus latifolia*, *Hagenia abyssinica* and sweet olive *Olea chrysophylla*. There is an extensive stand of pure bamboo *Arundinaria alpina* on Oldeani mountain and pencil cedar *Juniperus procera* on *Makarut mountain* in the west. The upland woodlands containing red thorn *Acacia lahai* and gum acacia (Bank, 2004; Ngorongoro Conservation Area [NCA], 2014).

The crater floor is mainly open shortgrass plains with fresh and brackish water lakes, marshes, swamps and two patches of Acacia woodland: Lerai Forest, with co dominants yellow fever tree *Acacia xanthophloea* and *Rauvolfia caffra*; and Laiyanai Forest with pillar wood *Cassipourea malosana*, *Albizzia gummifera*, and *Acacia lahai* (NCA, 2012). The undulating plains to the west are grass-covered with occasional umbrella acacia *Acacia tortilis* and *Commiphora africana* trees, which become almost desert during periods of severe drought. Blackthorn *Acacia mellifera* and zebra wood *Dalbergia melanoxylon* dominate in the drier conditions beside Lake Eyasi. These extensive grasslands and bush are rich, relatively untouched by cultivation, and support very large animal populations (United Nations Environment Programme [UNEP], 2011).

#### **4.3.3 Atmospheric Characteristics**

The conservation is a vast area with altitude ranging from 1009 to 3645 m (3310 to 11 959 feet). Both the rim (about 2300 m / 8530 feet) and floor (about 1700 m / 5577 feet) are at higher

altitudes and are colder than the overall conservation area (Briggs, 2012). Temperatures drop by about 6.5 °C for every 1000 m high (or 3.5 °F per 1000 feet). The difference is more noticeable during the night. Afternoons on the crater floor will be pleasant, but it can freeze on the crater rim at night. The rim also receives quite a lot of rain (NCA, 2014). The area experiences two wet seasons from October to November are the 'short' rains, followed by the 'long rains' from March to May (Fig. 17). Rainfall is experienced in the form of showers and thunder in the afternoon, yet it would be odd for it to rain the whole day. The crater never gets very hot during the day, but the crater rim gets cold, and it can freeze at night. Warm clothing for early morning game drives is a necessity (NCA, 2014).

The crater is generally dry in months of January and February, May to July and wet during months of April and August (Gadiye *et al.*, 2016). Both the rim (about 2300 m / 8530 feet) and floor (about 1700 m / 5577 feet) are at higher altitudes and are colder than the overall conservation area. Temperatures drop by about 6.5 °C for every 1000 m high (or 3.5 °F per 1000 feet). The difference is more noticeable during the night. Afternoons on the crater floor will be pleasant, but it can freeze on the crater rim at night. The rim also receives quite a lot of rain (Briggs, 2012).

Wet season – November to May: It gets warmer during the day when compared to the dry season, but mornings are still cold. Afternoon temperatures are usually around 23 °C/73 °F on the crater floor, while night temperatures are around 6 °C/43 °F on the crater rim. There is a chance for freezing temperatures (SafariBookings, 2013) as shown below:

- (i) November and December – 'Short rains' – These rains are highly unlikely to impact any safari as it won't rain all day. Showers usually happen in the afternoon. The 'short rains' last about one month and can occur anytime between October and December.
- (ii) January and February – It is not possible to guess when it will happen with accuracy but there is usually a time of dry weather between the wet seasons.
- (iii) March, April and May – 'Long rains' – This is when wetness is at its peak. Most days will have rain, but it will not last the entire day. The average maximum and minimum temperatures are 21 °C/70°F on the crater floor and 6 °C/43 °F on the crater rim. April and May could experience colder weather due to cold fronts (Fig. 17).

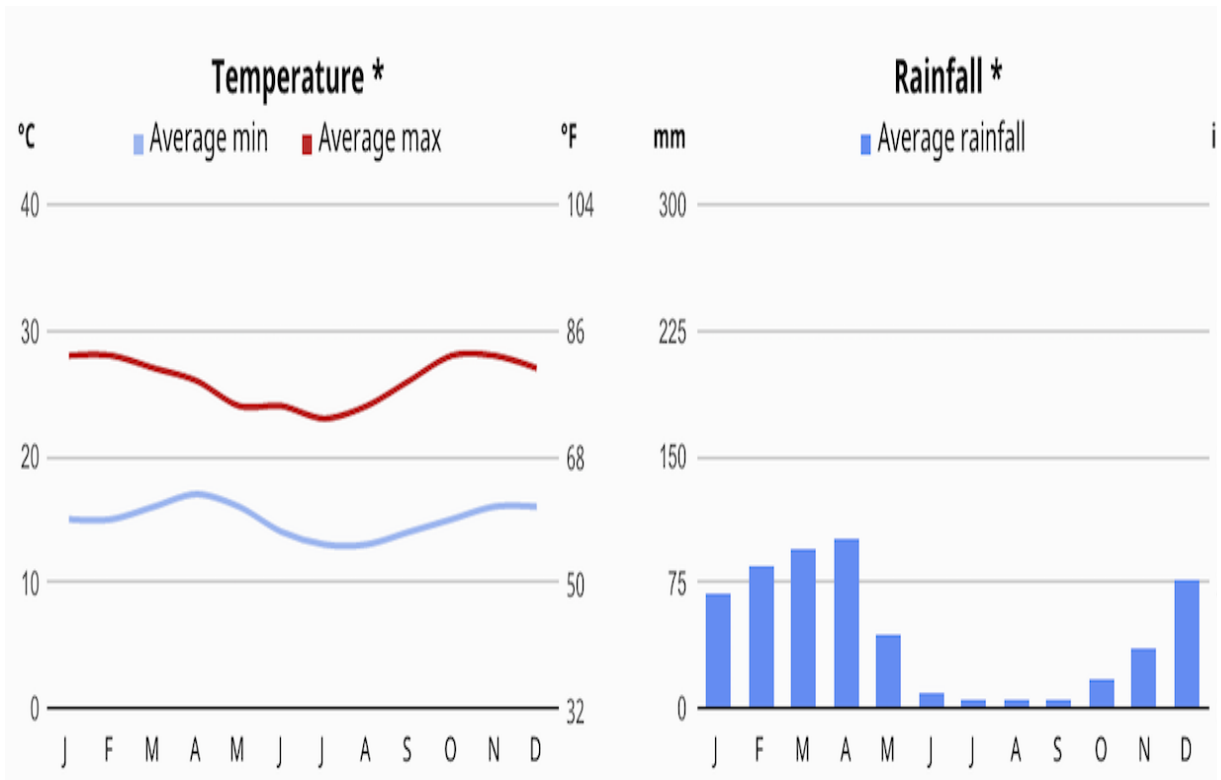

**Figure 17: The Ngorongoro Conservation Area Rainfall and Temperature Characteristics (Briggs, 2012)**

#### 4.3.4 Terrain Profile

The NCA terrain encompasses low and high lands (Fig. 18). The high lands include crater rim, peaks such as Lengai and Gol, and crater high lands. The low lands stretch beyond the crater to Serengeti plains including the vast plains of Ndutu in the northern-western part of the conservancy (NCA, 2014).





**Figure 18: Ngorongoro Conservation Area Terrain Overview (Google Earth)**

## **4.4 Signals and Attenuations**

### **4.4.1 Signals**

Since the wildlife tracking system is segmented in three parts namely GPS, GSM and WSN, transmissions occur within each of the segment and between the segments. The GPS signals include ranging signals, used to measure the distance to the satellite, a dataless acquisition aid, and navigation messages. There are two frequency bands allocated for GSM communication, one at 900 MHz and one at 1800 MHz. Sensor nodes often make use of Industrial, Scientific, and Medical (ISM) band, which gives free radio, spectrum allocation and global availability (Allan *et al.*, 2015). They furthermore, remarked that the possible choices of wireless transmission media are radio frequency (RF), optical communication (laser) and infrared. Lasers require less energy but need line-of-sight for communication and are sensitive to atmospheric conditions. Infrared, like lasers, needs no antenna but it is limited in its broadcasting capacity. Radio frequency-based communication is the most relevant that fits most of the WSN applications. The WSNs tend to use license-free communication frequencies: 173, 433, 868 and 915 MHz; and 2.4 GHz (Umesh, 2013).

### **4.4.2 Attenuations**

Three types of attenuation are studied in this paper which is vegetation attenuation, atmospheric attenuation and terrain attenuation. Vegetation attenuation is due to vegetation cover; atmospheric attenuation is caused by gases, moisture or rain in the atmosphere; and terrain attenuation is a result of signals obstruction by features such as mountains, hills or highlands.

## **4.5 Measurement Setup**

To get an actual picture of the conservation environment, a tour of the park was done to gather data through observation and measurement in areas less dangerous from wildlife within vicinity under guidance of the park ranger. Observation was useful in understanding the overall terrain, vegetation density and categories of vegetation, migration of animals, areas where rhinos and elephants can be found and their main areas of interests, high elevation points within the park, and weather in particular rain, fog and temperature variation. Measurements were done on vegetation heights to capture the tallest, average, and shortest using a tape measure. Also, pictures were taken using a digital camera to depict the various characteristics aforementioned.

### 4.5.1 Vegetation Attenuation

Vegetation is an indispensable feature of most outdoor wireless channel environments. The interaction between radio waves and vegetation has been researched for several decades. The appearance of the foliage medium in the path of the communication link has significant effects on the quality of the received signal, because discrete scatters such as the randomly distributed leaves, twigs, branches and tree trunks can cause attenuation, scattering, diffraction and absorption of the radiated propagating waves (Ghoraishi, 2013).

#### (i) Vegetation Attenuation Models

For years, experimental models have been developed to characterize the transmission of radio waves in the vegetation. The important advantage of those empirical models is simplicity and the framed model is firmly related to the particular measured data set (Ndzi *et al.*, 2012). These models usually provide either the average attenuation of the propagation signal or evaluate the link budget. Considerations in these models, e.g. frequency, incident angles, direct-path length through vegetation and other factors associated with the specific environment under which measurements were done, and calculated through regression curves fitted to data (Weissberger, 1982). Among many, the modified exponential decay model suggested and the European Cooperation in Science and Technology (COST) 235 model can be mentioned (Commission of European Union, 1996). These models are expressed as equations in exponential forms to give the specific attenuation as a function of path length and operating frequency. The attenuation of trees as a function of vegetation depth has been shown to be more accurately represented by dual slope attenuation functions (Schwering *et al.*, 1984; Tewari *et al.*, 1990; Al-Nuaimi, 1993). To accommodate this dual slope, an empirical nonzero gradient model was developed to follow the dual gradient of the measured attenuation curve (Stephens *et al.*, 1996; Ghoraishi, 2013). The initial slope describes the loss experienced by the coherent component, whereas the second slope describes the dominance of the incoherent component, which occurs at a much-reduced rate. An important disadvantage of the semi-empirical vegetated radio channel models, common to other approaches such as radiative transfer theory, is that their little account of the dynamic effects in the channel and no account of the wideband effects of the vegetation medium (Ghoraishi *et al.*, 2013).

Another approach in the analysis and prediction of the vegetated radio channel is ray-tracing (Tamir, 1967). These have to be carefully designed and used, taking into account the frequency of the radio wave, the dimension of interacting objects and their distance to the sources to fulfill

the far field condition (Ghoraishi *et al.*, 2013). Therefore, in different frequencies the mechanisms by which the wave propagates can vary dramatically. The scattering has been modeled deterministically in many different ways depending on the electrical density of the vegetative medium. At lower frequencies, where individual components of the vegetation (trunks, branches, twigs and leaves or needles) and their separations are small by comparison with the radio wavelength, considering the vegetation as a homogeneous dielectric slab, the propagation has been modeled in terms of a lateral wave at treetop heights. At frequencies above 200 [MHz] or so, a single slab becomes inadequate (Ghoraishi *et al.*, 2013). As the scale of the changes in density and structure of the vegetation become greater than the order of a wavelength and layered representations of the vegetation should be used (Li *et al.*, 1999).

A fully wave analysis of the radio wave propagating along mixed paths inside a four-layered forest model applicable to frequencies up to 3 [GHz] consists of four isotropic and homogeneous dielectrics (Cavalcante *et al.*, 1983; Li *et al.*, 1998). The first layer is the semi-infinite free-space, whereas the second layer represents the forest canopy. The third and fourth layers model the trunk and the semi-infinite ground plane respectively. As the distance between the transmitter and the receiver is very long, the radio wave propagation through the stratified forest is characterized by the lateral wave that mainly propagates on top of the canopy along the air-canopy interface. For short distances, however, such a propagation is denominated by the direct or coherent component (Ghoraishi, 2013). When the receiver is at a clearing distance from the dense vegetated area the edge of the forest is treated as a source of diffraction (Lagrone, 1977) and the uniform theory of diffraction (UTD) associating a double-diffracted component over the canopy and a transmission component which includes the exact calculation of refraction angles is also used (Matschek *et al.*, 1999).

To model the incoherent component which is the dominant propagation mechanism for long distances inside vegetation, theoretical models, which are more complicated but more generic and applicable to any arbitrary foliage wave propagation scenario are used. Two major approaches, namely the radiative transfer theory and the analytical theory, have been pursued to develop these models (Ishimaru, 1978; Tsang *et al.*, 2001). These two methods are closely related as they are addressing the same problem of the wave propagation in randomly distributed particles. In fact, the radiative transfer theory can be derived from analytical approach by applying some approximations (Ishimaru, 1978), and they have proven equivalent for the application of a radar in the forest canopies (Saatchi & McDonald, 1997).



In the method of radiative transfer theory, the vegetation medium is modeled as a statistical homogeneous random medium of scatterers which is characterized by parameters such as the absorption cross-section per unit volume, the scatterer cross-section per unit volume and the scattering function of the medium (Johnson & Schwering, 1985). The scattering function (phase function) is characterized by a narrow forward lobe and an isotropic background (Ghoraishi *et al.*, 2013). The model considers a plane wave incident from an air half space upon the planar interface of a vegetation half space. The basic equation of the radiative energy transfer theory is expressed in terms of the specific intensity for which the radiative transfer theory gives the specific value at a given point within the vegetation medium as a sum of a coherent component and an incoherent component (International Telecommunication Union [ITU], 2007). The ITU further remarked that the coherent component is reduced in intensity due to absorption and scattering of the incident wave, and the incoherent component due to the scattered wave. Each scatterer is assumed to have a directional scattering profile, or phase function. As the constituents of the tree are relatively large compared to the wavelength at micro- and millimeter wave frequencies, the scattering function is assumed to consist of a strongly scattering forward lobe, which can be assumed to be Gaussian with an isotropic background level.

The equation based on the radiative transfer theory allows the prediction of the attenuation curves in which the received signal is reduced linearly by scattering and absorption of the incident signal (Johnson, & Shwering, 1985). As the receiver is moved deeper into the vegetation, and the direct coherent component is reduced further still, the isotropically scattered component becomes significant. Due to the increase of scattering volume as moving deeper into the medium, the scattering signal level tends to be maintained, leading in turn to an attenuation rate which is significantly reduced at these depths (Didascalou *et al.*, 2000; Fernandes *et al.*, 2005). The model however, requires four input parameters namely the ratio of the forward scattered power to the total scattered power, the beam-width of the phase function, the combined absorption and scattering coefficient, and the albedo. These are extracted from path-loss measurement data so that the approach makes itself a semi-empirical model in essence. Direct computation of these parameters, such as the albedo and the phase function, is very difficult, because the vertical profile of the foliage is inhomogeneous, i.e. the distinction exists between the trunk layer and the crown layer, whereas the radiative transfer approach is generally applied to a homogeneous medium (Ghoraishi *et al.*, 2013).

In order to overcome this limitation, an improved version of the discrete radiative transfer is proposed for isolated vegetation specimens (Didascalou *et al.*, 2000; Fernandes *et al.*, 2005).

However, this requires discretization of the foliage into small cells which is numerically intractable for large propagation distances. The alternative approach in the problem of wave propagation in randomly distributed particles is the analytical approach. This is usually in the format of Foldy-Lax solution for point scatterers which has been widely used to estimate the signal attenuation in the foliage (Tsang *et al.*, 2001; Foldy, 1945). In this approach the Born approximation is applied to account only the first term in the equation as considering higher terms can complicate the computations prohibitively. It predicts the exponential decay of the radio field corresponding to the linear foliage path-loss (in dB) versus the wave propagation distance (Ghoraishi *et al.*, 2013).

The inhomogeneous forest structure can be represented by using a realistic-looking fractal tree model (Van Trees, 2002). The statistics of the received field are then obtained through a Monte Carlo technique which generates random forest structures according to prescribed statistical botanical features, such as tree height, branch and leaf orientation angles, and tree locations (Torrico *et al.*, 1998). Another approach is to model leaves as flat circular lossy dielectric discs, and branches as finitely long circular lossy dielectric cylinders. The disadvantage of the analytical approach stems from the fact that Born approximation accounts only for single scattering, which has been shown to overestimate the foliage path-loss at high frequencies or over long-distance propagation where the multiple-scattering effects become important (Koh *et al.*, 2003; Wang & Sarabandi, 2007). Another concern with this method is the required computation time. Computing foliage path-loss over long distances in a forested environment can be prohibitively time-consuming even with the single-scattering model. This difficulty can be circumvented by treating the forest as a statistical homogeneous medium along the direction of wave propagation and only analyzing the wave propagation behaviours in a typical block of forest, which can then be reused for all forest blocks (Wang & Sarabandi, 2007). Furthermore, a main concern in born approximation is its validity is restricted to scatterers with a dielectric permittivity close to unity and that the effect of multiple scattering from the discrete scatterers are not negligible (Blaunstein *et al.*, 2003). They furthermore, remarked that to overcome these limitations, the Feynman diagrams are converted to the set of expanded green functions presented in integral operator form is suggested as an alternative to born approximation.

To benefit from the ray-tracing and theoretical approaches at the same time, the model proposed by Rogers (2002) combines the effects of three individual propagation modes, i.e. diffraction from the side and top of the foliage, ground reflection and direct (through vegetation) propagation. In this approach the extent of the vegetation is modeled as rectangular hexahedrons

(boxes). The loss experienced by the diffracted waves over the vegetation as well as those around the vegetation are treated as double isolated knife-edge diffraction. If the ground reflection is passed through vegetation, the path loss due to propagation through vegetation is added to the reflection loss. The values for the permittivity and conductance of the ground are obtained from International Telecommunication Union, Radio communication Sector (ITU-R) recommendations. For the direct through vegetation propagation component the radiative transfer approach is adopted as per Rogers (2002), and the necessary parameters for specific geometries, species and frequencies are measured and provided in table 1. This model was adopted by ITU-R and later works published as recommendations of ITU-R have improved the tables of parameters for some kind of trees (ITU, 2004).

### ***International Telecommunication Union, Radio Communication Sector Vegetation Attenuation Model***

The ITU-R P.833-7 recommendation comprises of models essential for evaluating the effect of vegetation on radio wave signals and they are applicable for vegetation of various types. The models are very useful for signals in the range 30 MHz – 60 GHz. In short-range outdoor radio communication systems attenuation in vegetation can play a significant role and it is important to take that into consideration. However, the wide range of conditions and types of foliage makes it difficult to develop a generalized prediction procedure. The ITU-R P.833 introduces a general model of attenuation which is based on measurements (ITU, 2012).

### ***Obstruction by Woodland (Terrestrial Path with one Terminal in Woodland)***

For a Terrestrial radio path of which one terminal is located within woodland or similar widespread vegetation, the additional loss due to vegetation can be characterized on the basis of two parameters: The specific attenuation rate (dB/m) due primarily to scattering of energy out of the radio path, as would be measured over a very short path, and the maximum total additional attenuation due to vegetation in a radio path (dB) as limited by the effect of other mechanisms including surface-wave propagation over the top of the vegetation medium and forward scatter within it as per ITU Recommendation-R P 833-2 of 1992-1994-1999 (Fig. 19), and for the transmitter which is outside the woodland and the receiver is a certain distance,  $d$ , within it the excess attenuation,  $A_{ev}$ , due to the presence of vegetation is given by equation 6:

$$A_{et} = A_m \left[ 1 - \exp\left(\frac{-d\gamma}{A_m}\right) \right] \quad (6)$$

Where

$d$ : Length of path within woodland (m);

$\gamma$ : Specific attenuation for very short vegetative paths (dB/m);

$A_m$ : Maximum attenuation for one terminal within a specific type and depth of vegetation (dB).

Also it may be noted that  $A_m$  is equivalent to the clutter loss often quoted for a terminal obstructed by some form of ground cover or clutter (ITU Recommendation-R P 833-2 of 1992-1994-1999). The maximum attenuation,  $A_m$ , as limited by scattering from the surface wave, depends on the species and density of the vegetation, plus the antenna pattern of the terminal within the vegetation and the vertical distance between the antenna and the top of the vegetation (ITU Recommendation R P.833-4 of 1992-1994-1999-2001-2003). The value of specific attenuation due to vegetation,  $\gamma$  dB/m, depends on the species and density of the vegetation (ITU Recommendation-R P 833-2 of 1992-1994-1999).

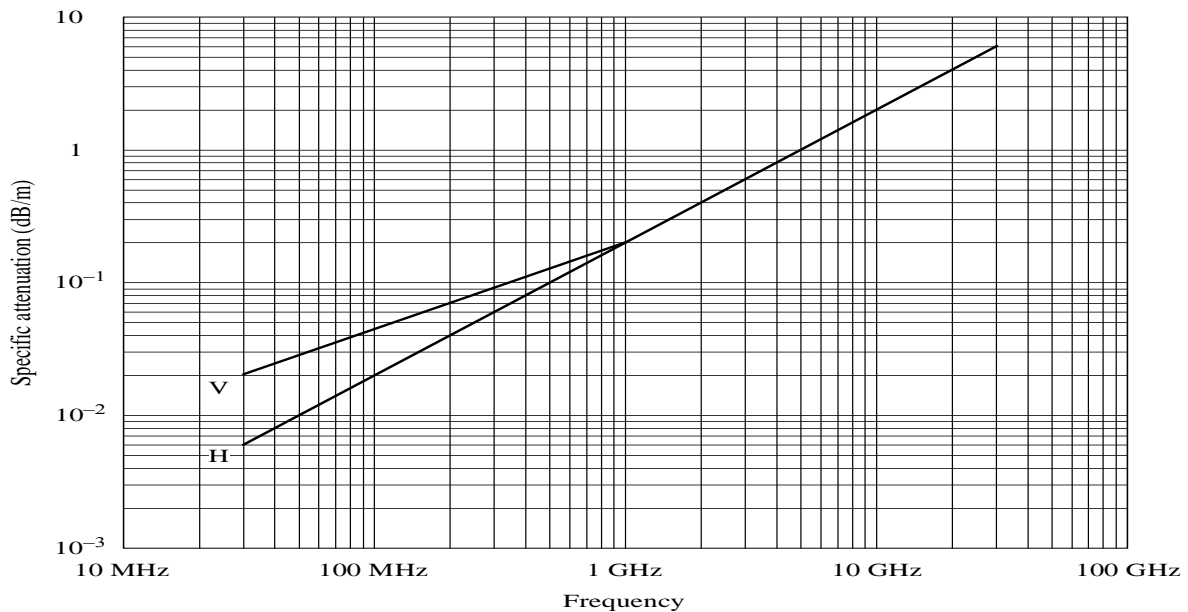

**Figure 19: Specific Attenuation due to Woodland (V: Vertical Polarization, H: Horizontal Attenuation)**

The maximum attenuation depends on frequency and is expressed as:

$$A_m = A_1 f^\alpha \quad (7)$$

Where  $f$  is the frequency (MHz) and values of  $\alpha$  and  $A_1$  are obtainable by experimentation.

**Table 1: Estimation of  $A_m$  based on Equation (7): Sample Experiments**

| Experimental environment (Vegetation)       | Antenna specs  | Frequency, $f$ (MHz) | Antenna height (m) | Woodland height (m) | $A_1$ | $\alpha$ | $A_m$                             |
|---|--|----------------------|--------------------|---------------------|-------|----------|-----------------------------------|
| Tropical trees                              |  | 900 – 1800           | 2.4                | 15                  | 0.18  | 0.752    | <b><math>0.18f^{0.752}</math></b> |
| Forest with variety of trees                | Tx: $\lambda/2$ dipole (25m)<br>Rx: $\lambda/4$ monopole | 900 – 2200           | 1.6                | 15                  | 1.15  | 0.43     | <b><math>1.15f^{0.43}</math></b>  |
| Forest with coniferous-deciduous vegetation | $\lambda/4$ dipole                                       | 105.9 – 2117.5       | 1.5                | 12 - 16             | 1.37  | 0.42     | <b><math>1.37f^{0.42}</math></b>  |

Considering NCA vegetation characteristics and areas where rhinos and elephants spend their time within the conservancy, the first experimental case is more relevant for the mobile communication segment. Thus equation (7) becomes (8) as shown in Table 1 with  $A_m = 14.77\text{ dB}$  at 900 MHz and  $17.03\text{ dB}$  at 1800 MHz:

$$A_m = 0.18f^{0.752} \quad (8)$$

### ***Cluster Losses***

Also, it may be noted that  $A_m$  is equivalent to the clutter loss regularly quoted for a terminal obstructed by some form of ground cover or clutter (ITU Recommendation-R P 833-2 of 1992-1994-1999). According to International Telecommunication Union (ITU, 2015) considerable benefits, in terms of protection from interference, can be derived from the additional diffraction losses available to antennas which are imbedded in local ground clutter (buildings, vegetation, etc.). This procedure allows for the addition of such clutter losses at either or both ends of the path in situations where the clutter scenario is known. It predicts a maximum additional loss at either end of the path, applied via an S-shaped interpolation function intended to avoid an overestimate of the shielding loss (ITU, 2011). The maximum additional loss is 20 dB above 0.9 GHz, and progressively less at lower frequencies, down to 5 dB at 0.1 GHz. where there are doubts as to the certainty of the clutter environment this additional loss should not be included. Where the correction is used, care should be taken not to expect high clutter losses in a high-rise urban area consisting of isolated tall buildings separated by open spaces. Lower clutter losses are often observed in such areas compared to more traditional city centers comprising lower but more connected blocks of buildings (ITU, 2015).

Table 2 indicates the clutter (or ground cover) categories as defined in Recommendation ITU-R P.1058 for which the height-gain correction can be applied. The nominal clutter height,  $h_a$  (m) and distance from the antenna,  $d_k$  (km) are deemed to be “average” values most representative of the clutter type. However, the correction model has been made conservative in recognition of the uncertainties over the actual height that are appropriate in individual situations. Where the clutter parameters are more accurately known they can be directly substituted for the values taken from Table 2.

▪ **The height-Gain Model**

The additional loss due to protection from local clutter is given by the expression below:

$$A_h = 10.25e^{d_k}F_{fc} \left( 1 - \tanh \left[ 6 \left( \frac{h}{h_a} - 0.625 \right) \right] \right) - 0.33 \quad (9)$$

Where:

$$F_{fc} = 0.25 + 0.375\{\tanh[7.5(f - 0.5)]\} \quad (10)$$

And:

$d_k$  : Distance (km) from nominal clutter point to the antenna

$h$  : Antenna height (m) above local ground level

$h_a$  : Nominal clutter height (m) above local ground level.

**Table 2: Nominal Clutter Heights and Distances**

| Clutter (ground – cover) category     | Nominal height, $h_a$ (m) | Nominal distance, $d_k$ (km) |
|---------------------------------------|---------------------------|------------------------------|
| Coniferous trees (irregularly spaced) | 20                        | 0.05                         |
| Coniferous trees (regularly spaced)   |                           |                              |
| Tropical rain forest                  | 20                        | 0.03                         |
| Suburban                              | 9                         | 0.025                        |
| Deciduous trees (irregularly spaced)  |                           |                              |
| Deciduous trees (regularly spaced)    | 15                        | 0.05                         |
| Mixed tree forest                     |                           |                              |
| High crop fields                      |                           |                              |
| Park land                             | 4                         | 0.1                          |
| Irregularly spaced sparse trees       |                           |                              |
| Orchard (regularly spaced)            |                           |                              |

### *Single Vegetative Obstacle*

- **At or Below 3 GHz**

Equation (7) does not cover for a radio path obstructed by a single vegetative obstacle where both terminals are outside the vegetative medium, such as a path transient through the canopy of a single tree (ITU Recommendation-R P 833-2 of 1992-1994-1999). At VHF and UHF, where the specific attenuation has moderately low values, and mainly where the vegetative part of the radio path is moderately short, this situation can be modelling on an approximate basis in terms of the specific attenuation and a maximum limit to the total excess loss (ITU Recommendation-R P 833-2 of 1992-1994-1999).

$$A_{et} = d\gamma \quad (11)$$

Where:

$d$  is the length of path within the tree canopy (m)

$\gamma$  is the Specific attenuation for very short vegetative paths (dB/m) and

$A_{et\leq}$  Lowermost excess attenuation for other paths (dB)

The limit of a maximum value for  $A_{et}$  is essential since, if the specific attenuation is sufficiently high, a lower-loss path will exist around the vegetation. An approximate value for the minimum attenuation for other paths can be calculated as though the tree canopy were a thin finite-width diffraction screen using the method of (ITU Recommendation-R P 833-2 of 1992-1994-1999).

- **Above 1GHz**

In order to estimate the total field, the diffracted, ground reflected and through-vegetation scattering components are first calculated and then combined. The diffracted components consist of those over the top of the vegetation and those around the sides of the vegetation. These components and the ground reflected component are calculated using ITU-R Recommendations ITU-R P.526, § 4.2. The through or scattered component is calculated using a model based upon the theory of radiative energy transfer (RET).

- **Above 5 GHz**

Attenuation through vegetation is important for broadband wireless access systems. These systems are typically based on a star network, with a well-positioned hub (or base station) serving many individual users with rooftop antennas. In many cases, signals will be obscured by vegetation close to the user antenna. For simplicity, the hub antenna will be referred to as the



transmitter and the user antenna as the receiver (ITU Recommendation-R P 833-2 of 1992-1994-1999).

The model only considers propagation through vegetation. The attenuation experienced will be the minimum of the level determined from the following model and the signal diffracted around the vegetation which may be estimated using (ITU Recommendation-R P 833-2 of 1992-1994-1999).

Referring to (ITU Recommendation-R P 833-2 of 1992-1994-1999) an empirical model of propagation through vegetation has been developed for frequencies above 3 GHz. The model gives the attenuation through vegetation as a function of vegetation depth, taking into account the dual slope nature of the measured attenuation versus depth curves. The model was derived from a database of measured data over a range of frequencies 9.6-57.6 GHz, but also takes into account the site geometry in terms of the extent of illumination of the vegetation, defined by the illumination width,  $W$ . The attenuation for a vegetation depth,  $d$  (m), is given by:

$$A = \frac{R_{\infty}}{f^a W^b} d + \frac{k}{W^c} \left( 1 - \exp \left( - \frac{(R_0 - R_{\infty}) W^c}{k} d \right) \right) \quad (12)$$

Where  $f$  is the signal frequency (GHz) and  $a, b, c, k, R_0$  and  $R_{\infty}$  are constants as given in Table 2.

**Table 3: Constant Values for Equation (6)**

| Constant parameter | In leaf | Out of leaf |
|--------------------|---------|-------------|
| $A$                | 0.7     | 0.64        |
| $B$                | 0.81    | 0.43        |
| $C$                | 0.37    | 0.97        |
| $K$                | 68.8    | 114.7       |
| $R_0$              | 16.7    | 6.59        |
| $R_{\infty}$       | 8.77    | 3.89        |

In order to account for the site geometry (Fig. 20), one must consider the extent of illumination of the vegetation (ITU Recommendation-R P 833-2 of 1992-1994-1999), and this may be characterized by the illumination width,  $W$ , as shown in Fig. 19. The  $W$  is the maximum horizontal dimension within the vegetation common to both transmitter and receiver beam

widths. As this model is an empirical fit to measured data, it should only be applied within the bounds provided by equation 7.

$$1 < W < 50 \quad (m) \quad (13)$$

The vertical dimension is not currently modelled. It is assumed that the vegetation fills the vertical dimension of the receiver antenna (ITU Recommendation-R P 833-2 of 1992-1994-1999).

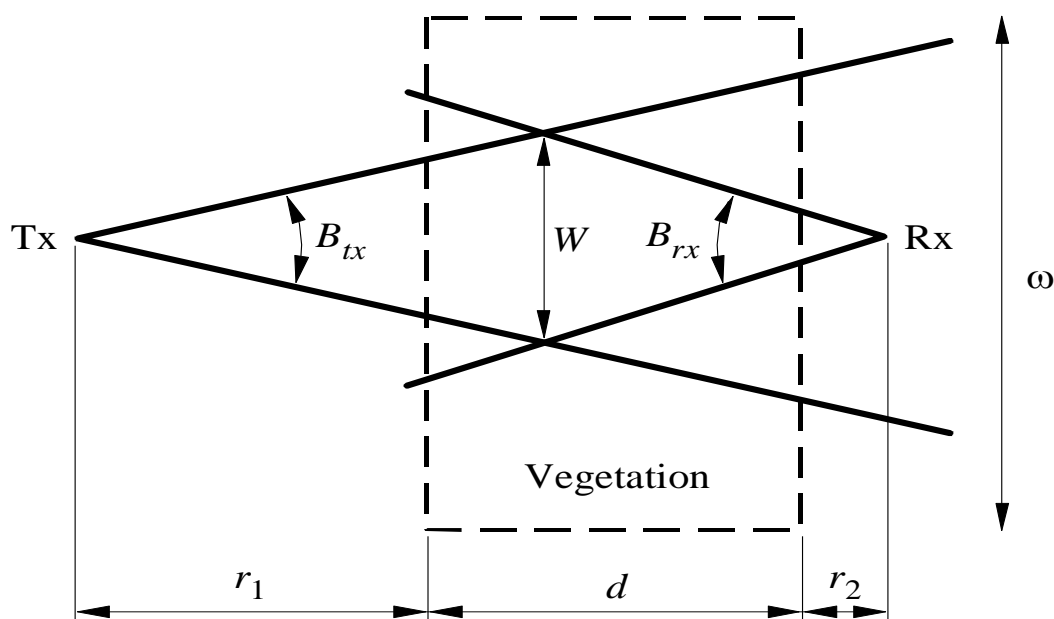

**Figure 20: Signal through Vegetation Path Geometry**

$B_{tx}$  and  $B_{rx}$  are the 3 dB beam widths of the transmitter antenna and the receiver antenna, respectively,  $\omega$  is the physical width of the vegetation,  $d$  is the depth of vegetation and  $r_1$  and  $r_2$  are the distances to the vegetation from the transmitter and receiver, respectively. It is assumed that the receiver is closest to the vegetation (ITU Recommendation-R P 833-2 of 1992-1994-1999).

Based on (ITU Recommendation-R P 833-2 of 1992-1994-1999)  $W$  is the maximum effective coupling width between the transmitter and receiver antennas that lies within the vegetation medium (i.e. that given at the largest measured vegetation depth), defined by:

$$W = \min \left[ \begin{array}{c} \frac{(r_1 + d + r_2) \tan(B_{tx}) \tan(B_{rx})}{\tan(B_{tx}) + \tan(B_{rx})} \\ (r_1 + d) \tan(B_{tx}) \\ (d + r_2) \tan(B_{rx}) \\ \omega \end{array} \right] \quad (14)$$

In practice  $r_1 \gg r_2$  and the beam width of the receiver,  $B_{rx}$ , is expected to be only a few degrees. Under these conditions the parts of equation (10) containing  $r_2$  will not normally be required (ITU Recommendation-R P 833-2 of 1992-1994-1999).

## 4.5.2 Atmospheric Attenuation

### (i) Atmospheric Gases

According to (Hum, 2017) uncondensed water vapour and oxygen can be strongly absorptive of radio signals, especially at millimetre-wave frequencies and higher (tens to hundreds of GHz). This is due to the existence of absorption lines in the elements composing atmospheric gases, or bands of frequencies where these gases naturally absorb photon energy (Hum, 2017). This occurs at the resonance frequencies of the molecules themselves. The most important gases to consider are water vapour and oxygen. They can significantly attenuate microwave and millimetre wave signals to the point where link margins must be widened substantially, or propagation limited to very short ranges (Hum, 2017).

An attenuation or absorption constant is defined for oxygen and water vapour, and usually has units of dB/km. The resulting attenuation is in excess of the reduction in radiated signal power due to free-space loss (The equations 14 and 15 are approximate expressions for the attenuation constants of oxygen and water (in dB/km), as defined by the International Telecommunications Union (Hum, 2017).

$$a_0 = \begin{cases} 0.001 \left[ 0.00719 + \frac{6.09}{f^2 + 0.227} + \frac{4.81}{(f - 57)^2 + 1.50} \right] f^2 & f < 57 \text{ GHz} \\ a_0(57 \text{ GHz}) + 1.5(f - 57) & f \geq 57 \text{ GHz} \end{cases} \quad (15)$$

$$a_{\omega} = 0.0001 \left[ 0.050 + 0.0021\rho + \frac{3.6}{(f - 22.2)^2 + 8.5} + \frac{10.6}{(f - 183.3)^2 + 9.0} + \frac{8.9}{(f - 325.4)^2 + 26.3} \right] f^2 \rho \quad f < 350 \text{ GHz} \quad (16)$$

Where  $f$  is the frequency in GHz,  $\rho$  is the water vapour density in g/m<sup>3</sup> (typically 7.5 g/m<sup>3</sup> at sea level), and  $a_0(57 \text{ GHz})$  is the first expression evaluated at 57 GHz. Both constants are in dB/km. For propagation paths that are mostly horizontal, the attenuation constants are fairly constant, and the total attenuation is simply found by multiplying the attenuation constant (Hum, 2017) by the path distance  $L_{km}$ :

$$A_a = [a_0 + a_{\omega}]L_{km} = a_a L_{km} \quad (\text{units: dB}) \quad (17)$$

In general, the attenuation constants are functions of altitude, since they depend on factors such as temperature and pressure. The effect of attenuation on millimetre-wave communication systems is significant. For terrestrial systems such as local multipoint communication systems, the attenuation limits the ranges or cell size of such systems. For satellite systems, the attenuation can play a strong role in determining the overall system link budget (Hum, 2017). It is further emphasized that that GPS and GSM networks use frequencies below 57GHz and 350GHz, thus equation 18 which is derived from equations 11 and 12 is most suitable for the respective networks (Gallery *et al.*, 1983).

$$A = \left[ 0.001 \left[ 0.00719 + \frac{6.09}{f^2 + 0.227} + \frac{4.81}{(f - 57)^2 + 1.50} \right] f^2 + 0.0001 \left[ 0.050 + 0.0021\rho + \frac{3.6}{(f - 22.2)^2 + 8.5} + \frac{10.6}{(f - 183.3)^2 + 9.0} + \frac{8.9}{(f - 325.4)^2 + 26.3} \right] f^2 \rho \right] L_{km} \quad (18)$$

## (ii) Rain Attenuation

Given the highly variable nature of rain with time, and its variation from location to location, it is possible to predict the occurrence of rain with certainty (Hum, 2017). Therefore, the immediate goal when studying rain attenuation is to determine the percentage of the time that a given amount of rain attenuation will be exceeded at a certain location. This information can be used

to plan for “rain margin” in link budgets so guarantee that links operate a certain percentage of the time (Hum, 2017).

When a plane wave strikes a raindrop, some of the energy in the plane wave is absorbed by the water (since it is a lossy dielectric), while some of it is scattered (Hum, 2017). Scattering loss is relevant because power may be scattered in directions other than the desired direction of interest. These two phenomena lead to an overall effect called “extinction” by the raindrop. Characterizing the effect of rain attenuation on a communication system is quite involved, for two reasons in accordance to Hum (2017):

- (a) The calculation of the scattering and attenuation of a plane wave by a water droplet is quite complex, and depends to some extent on the assumed shape of the water droplet: assuming the droplet is a spheroid is a good starting point, but in general an ellipsoid shape is assumed and the ellipse falls at an angle (which is called canting). The net result is that the attenuation depends strongly on the type of rain, wind conditions, frequency, and incident wave polarization. Wave passing through rain falling at an angle may also be repolarized, i.e. converted from one polarization to another, though we will not delve into this process here (Hum, 2017).
- (b) The rainfall process is stochastic. Therefore, we are less interested in the instantaneous characteristics of the rain attenuation and more with the cumulative effect in terms of the probability that outages will occur with a given link budget (Hum, 2017).

According to Hum (2017) the empirical formulas are useful for predicting the attenuation constant at any given time. One such expression is:

$$a_r = kR^\alpha \quad (\text{units: dB/Km}) \quad (19)$$

Where  $R$  is the rain rate in mm/hour, and  $k$  and  $\alpha$  are constants that depend on the frequency, and temperature of the rain. According to Hum (2017) the total rain attenuation through a cell is computed using:

$$A_r = a_r L_{r,eff} \quad (\text{units: dB}) \quad (20)$$

Where  $L_{r,eff}$  is the effective path length through the rain cell. Note that this formula assumes that the rain attenuation is uniform through the cell. In practice, this is not the case and  $L_{r,eff}$  is

empirically adjusted higher or lower so that that the rain can be treated as homogeneous within the cell (Hum, 2017).

Constants in the equation have been evaluated empirically based on measured statistics at radio sites. Multiple models exist for these constants, ranging from tables, graphs, to empirical formulas.

The International Telecommunications Union (ITU, 1992)-R provides simple attenuation models for rainfall that are very statistically accurate and are used worldwide. Table 1 shows values for  $k$  and  $\alpha$  for frequencies between 4 and 50 GHz (Hum, 2017). The suffixes V and H refer to vertical and horizontal polarization, respectively. It is interesting to note that the attenuation rate is polarization-dependent, which is a consequence of the raindrop having an elongated shape in the vertical direction, which in turns produces different scattering behavior for vertical polarization and horizontal polarization. For values in between frequency points, interpolation can be employed whereby a logarithmic scale for frequency and  $k$  are used, and a linear scale for  $\alpha$  is used (Hum, 2017); also, the coefficients can be modified for other polarizations according to :

$$k = \frac{k_V + k_H + (k_H - k_V) \cos^2 \theta \cos 2\tau}{2} \quad (21)$$

And

$$\alpha = \frac{k_V \alpha_V + k_H \alpha_H + (k_H \alpha_H - k_V \alpha_V) \cos^2 \theta \cos 2\tau}{2} \quad (22)$$

Where  $\theta$  is the elevation angle of the path, and  $\tau$  is the polarization tilt angle ( $\tau = 45^\circ$  for circular polarization). Rain attenuation can produce large changes in the received signal power, forcing margins in a link budget to be much larger than if the rain did not exist. The 20-30 dB changes in received signal power can produce outages for significant periods of time if the link budget margin does not adequately cover the ranges of attenuation expected over the course of normal weather patterns (Hum, 2017).

### (iii) Terrain Attenuation

For ground communications, the local terrain features significantly affect the propagation of electromagnetic waves (ITU, 2014). When the terrain is very flat, only potential multipath reflections and earth diffraction, if near the radio horizon, need to be considered. Varied terrain, on the other hand, can produce diffraction loss, shadowing, blockage, and diffuse multipath, even

over moderate distances (ITU, 2014). Obviously hills which obstruct the path will considerably attenuate the signal, often making reception impossible. Additionally, at low frequencies the composition of the earth will have a marked effect. For example, on the Long Wave band, it is found that signals travel best over more conductive terrain, e.g. sea paths or over areas that are marshy or damp. Dry sandy terrain gives higher levels of attenuation (Van Tree, 2002).

The hilly parts present significant obstructions to signals especially the leese of mountains. Those signals, when they come to a mountain, will be blocked very effectively - because it is so big. Mountains cause diffraction of signals. To prevent blockage presented by mountains, the resolve would be having transceivers on either side of the mountains. Mountains cause the knife-edge effect which is an outgrowth of the half-plane problem. In electromagnetic wave propagation, the knife-edge effect or edge diffraction is a redirection by diffraction of a portion of the incident radiation that strikes a well-defined obstacle such as a mountain range or the edge of a building. The knife-edge effect is explained by Huygens–Fresnel principle, which states that a well-defined obstruction to an electromagnetic wave acts as a secondary source and creates a new wave front. This new wave front propagates into the geometric shadow area of the obstacle.

### 4.5.3 Terrain Models

This model provides a measure of the median path loss as a function of distance and terrain irregularity. The difference about the median due to other effects are then treated separately (ITU, 2014). There are several models which have been developed, the ones frequently used to study terrain impact on propagation of radio waves are as explained below.

#### (i) Egli Model

Based on Egli (1957) is not a universal model but can be easily implemented and comply with empirical data make it a commonly used, mainly for a first analysis as well as for median path loss over irregular terrain:

$$L_{50} = G_b G_m \left[ \frac{h_b h_m}{d^2} \right]^2 \beta \quad (23)$$

Where

$G_b$  is the gain of the base antenna

$G_m$  is the gain of the mobile antenna

$h_b$  is the height of the base antenna

$h_m$  is the height of the mobile antenna

$d$  is the propagation distance

$$\beta = \left(\frac{40}{f}\right)^2 \quad \text{where } f \text{ is in MHz} \quad (24)$$

Egri-model typically used for calculations of entire path loss, while the foliage and models are used for calculation of the loss in addition to free-space loss. Also, the model is used for terrains which is irregular and does not address vegetation (Chebil *et al.*, 2013). While alike to the ground-bounce loss formula, the Egri model is not constructed on the same physics, but rather is an empirical match to measured data (Seybold, 2005). By assuming a log-normal distribution of terrain height, Egri generated a family of curves showing the terrain factor or adjustment to the median path loss for the desired fade probability (ITU, 2014). Through this way, the analyst can determine the mean or median signal level at a given percentage of locations on the circle of radius  $d$ . In another way, the Egri model provides the median path loss due to terrain loss. If a terrain loss points other than the median (50%) is desired, the adjustment factor in Db (ITU, 2014). The Egri model (Equation 25) provides a nice, closed-form way to model terrain effects, but since it is a one-size-fits-all model, it should not be expected to provide precise results in all situations (ITU, 2014):

$$L_{50} = G_b G_m \left[ \frac{h_b h_m}{d^2} \right]^2 \left( \frac{40}{f} \right)^2 \quad 25$$

#### 4.5.4 International Telecommunication Union Terrain Model

This model determines media path loss based on diffraction theory. The model represents the excess terrain loss, beyond free space loss (ITU, 2014). The ITU loss model is given by the following equation:



$$A_d = -20h/F_1 + 10 \quad (\text{dB}) \quad (26)$$

Where  $h$  is the height difference between the most significant path blockage and the line-of-sight path between the transmitter and the receiver. If the blockage is above the line of sight, then  $h$  is negative. The  $F_1$  is the radius of the first Fresnel zone and is given by as per (Seybold, 2015):

$$F_1 = 17.3 \sqrt{\frac{d_1 d_2}{fd}} \quad (\text{m}) \quad (27)$$

Where

$d_1$  and  $d_2$  are the distances from each terminal to the obstruction in km.

$d$ : is the distance between the terminals in km .

$f$ : is the frequency in GHz.

$h/F_1$  is the normalized terrain clearance ( $h/F_1 < 0$  when the terrain blocks the line of sight). This model is generally considered effective for losses above 15 dB, but it is acceptable to extrapolate it to as little as 6 dB of loss (ITU, 2014). In accord to ITU (2014) when there is no specific information about the location of any obstruction within the line of sight, the obstruction is assumed to occur at the midpoint of the path,  $d/2$ .  $F_1$  is approximated to:

$$F_1 = 17.3 \sqrt{\frac{d}{4f}} \quad (\text{m}) \quad (28)$$

$$A = \frac{-20h}{17.3 \sqrt{\frac{d}{4f}}} + 10 \quad (29)$$

#### 4.5.5 Longley Rice Model

This is among of the comprehensive model developed on 1960s (Horn & Johnson, 1985; MacKay, 1992; Seybold, 2005). The model is created based on data collected within frequencies of 40 MHz and 100 GHz (Ostlin *et al.*, 2003). This model is normally applied in computer programme due to its detail level (Seybold, 2005). Many commercial simulation products include the Longley–Rice model for their terrain modeling. The Longley–Rice model has two models, point-to-point and area. The point-to-point model makes use of detailed terrain data or

characteristics to predict the path loss, whereas the area model uses general information about the terrain characteristics to predict the path loss (Östlin, 2009; Kasampalis *et al.*, 2013).

Most radio propagation models, especially the general-purpose ones can be characterized as being either a "point-to-point" model or an "area prediction" model. The difference is that a point-to-point model demands detailed information about the particular propagation path involved while an area prediction model requires little information and, indeed, may not even require that there be a particular path. The National Telecommunications and Information Administration (NTIA) Longley-Rice model used by the radio propagation software is called Institute for Telecommunication Sciences (ITS) Irregular Terrain Model (ITM). The ITM software was developed in three languages: TeX (tau epsilon chi), FORTRAN (Formula Translation) and C++ (An Object-oriented Programming Language Based On C). The ITS model of radio propagation for frequencies between 20 MHz and 20 GHz is a general-purpose model that can be applied to a large variety of engineering problems. The model, which is based on electromagnetic theory and statistical analyses of both terrain features and radio measurements, predicts the median attenuation of a radio signal as a function of distance and the variability of the signal in time and in space. The model is described in the form used to make "area predictions" for such applications as preliminary estimates for system design, military tactical situations and surveillance, and land-mobile systems.

#### 4.6 Multi-objective Optimization of the Model

The equation below was taken from equation-1; which gives the attenuation caused by the presence of vegetation while the next question was taken from the ITU-Model. The aim of this choice is to create a multi-objective function and optimize it for the GSM frequency. Since the models are supposed to work on the forest where there is a seasonal variation. An average value for each parameter was calculated so as to have the minimum deviation of the model when the seasons in the forest changes (Equations 30 and 31):

$$\mathbf{F(A_{et})} = \mathbf{A_1 f^\alpha \left[ 1 - \exp\left(\frac{-d\gamma}{A_m}\right) \right]} \quad 30$$

$$\mathbf{A_d} = \mathbf{-20h / \left[ 17.3 \sqrt{\frac{d_1 d_2}{fd}} \right] + 10} \quad 31$$

Where

$d$ : is the path length within woodland (m);

$\gamma$ : is the specific-attenuation for very short vegetative paths (dB/m);

$A_m$ : is the maximum attenuation for single terminal within a specific type and depth of vegetation (dB) as per (ITU Recommendation-R P 833-2 of 1992-1994-1999)

$\alpha$ : Replaced with Average attenuation on Table 1

$R$ : is the rain rate in mm/hour

$k$  &  $\alpha$ : are constants that depend on the frequency (Hum, 2010)

$L_{r,eff}$  : the effective path length through the rain cell  $d_1$  and  $d_2$  is the terminal distance to the obstruction in km as per (ITU, 2014)

$d$ : is the terminals distance in km

$f$ : frequency in GHz

### Assumptions

Parameters substituted are as follow:

$d_1=0.05$  km,  $d_2=0.02$  km,  $d=0.07$  km,  $h= 4$  m

$\alpha = 0.534$  (average of attenuation obtained at table 4.1)

$A_1= 0.9$  (average of  $A_m$  values)

However;

$$\text{Since } \mathbf{F(A_{et})} = \mathbf{A_1 f^\alpha \left[ 1 - \exp\left(\frac{-dy}{A_m}\right) \right]} \quad 32$$

It assumed that  $\left[ 1 - \exp\left(\frac{-dy}{A_m}\right) \right] \approx 1$

32

The final objective functions are show below

$$\mathbf{F(A_{et})} = \mathbf{A_1 f^\alpha} \quad 33$$

$$\mathbf{F(A_d)} = - \frac{20h}{\left[ 17.3 \sqrt{\frac{d_1 d_2}{fd}} \right]} + 10 \quad 34$$

A Multi-objective function was created using Matlab Program as shown below:

```
function f = serengeti_multiobjective(f)
f1 = 0.9*f.^ (0.34);
f2 = -12.23.*sqrt(f)+10;
end
```

A Constrained objective function was also created for optimization using Genetic Algorithm Using Multi-objective function

```
FitnessFunction = @serengeti_multiobjective;
numberOfVariables = 1;
lb = 900000000;
ub = 2100000000;
niter=1000;
[x, fval] = gamultiobj (FitnessFunction, numberOfVariables, lb, ub)
```

```
%%
% Plot two objective functions on the same axis
fmin=900*10^6;
fmax=2100*10^6;
f = fmin:50: fmax;
f1 = 0.9*f.^0.34;
f2 = -12.23*sqrt(f)+10;
plot (f, f1);
hold on;
plot (f, f2,'r');
grid on;
title ('Plot of objectives ''0.9*freq.^0.34'' and ''-
12.23*sqrt(freq)+10''');
```

#### 4.7 Results and Discussions

An optimization using genetic algorithm was done using Matlab software. Figure 21 shows fitness value and the generation for the algorithm which ended up to 50 generations. The optimization shows that; the best value is 900 MHz while the Mean best value is 929 MHz.

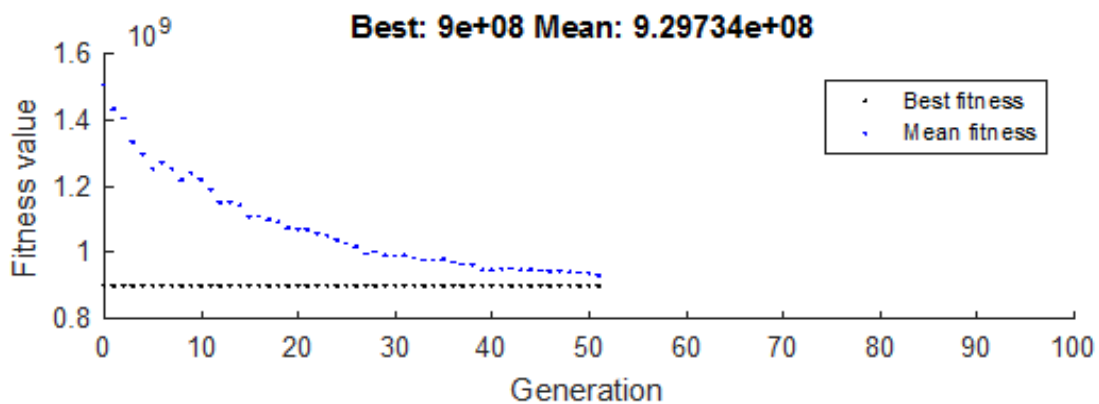

Figure 21: Fitness value against generation for the algorithm

As per results, since the optimization constrained frequency was from 900-1800-2100 MHz, the study proposes to use 929 MHz frequency for the transmission and reception of bio-signals from the elephants/rhino to the Base-Station at Serengeti National Park.

#### **4.8 Conclusion**

This paper has presented analysis of wildlife tracking system attenuation models. The objective of the study was to ascertain the best model for application in wireless sensor network planning and deployment in national park areas especially in Ngorongoro Conservation Area. A multi-objective function was developed for optimization of frequency for the GSM network since the models are supposed to work on the forest where there is a seasonal variation. The result shows that wireless sensor node deployment much consideration should be on optimized frequency value to maximize range and improve the signal to noise ratio with respect to seasonal variations.

## CHAPTER FIVE

### **A Mobile Platform for Wildlife Conservation and Research Information Management with Real-Time Monitoring**

#### **Abstract**

Rangers and researchers often monitor the movement of elephants and rhinos in the wild by using tracking systems that record their movement patterns, locations and interaction behaviour. The existing commercial systems for monitoring elephants and rhinos utilize collars with GPS sensors, and they use only PC as a monitoring terminal, which performs well but does not give portability. The GPS sensors record location data every few hours, enabling researchers to approximate the interaction behaviour of tracked elephant/rhino with their GPS locations. However, the coarse granularity of periodically recorded GPS location data provides only limited precision for determining interaction behaviour. In this study an Intelligent Real Time Monitoring Software was designed by using android platform to monitor elephants/rhino interaction behaviour more precisely in harsh wilderness environments. The designed system combines the functionalities of both GPS and heartbeat sensors. This system was designed and built to be able to operate robustly for a period of up to several months for continual tracking and monitoring of the locations and interaction behaviours of the wild animals in harsh environments. The data can be viewed on mobile handsets anywhere from the world. Google Application Programming Interface was used to find optimal path for rangers and drones moving to the areas where there is possibility of poaching incidences. The present study successfully deployed the collar on dog as pilot study. This paper, describes how we designed and built this system and evaluate its successful operation on a piloted study.

#### **5.1 Introduction**

According to Wall *et al.* (2014) the growth of global communication systems and advancement of animal tracking technology has made it possible on development of real-time system for collection of positional data recorded by sensors tracking units attached on animals. The recorded data from the sensors can produced innovation on ecological monitoring and wildlife conservation. In this research work five broad approaches for algorithmic for rhinos/elephants monitoring in real time has been presented. Which are horns synchronization, proximity, geo-fencing, movement rate, and immobility intended to observe aspects of rhinos/elephants spatial activity and behaviour not possible with conventional tracking systems. Application of the five

algorithmic approaches to the real-time monitoring (Wall *et al.*, 2014) can eliminate poaching activities in Tanzania National Parks which is at high rate. This research work has also provided details on the cloud-based monitoring system including infrastructure, data collection, and developed mobile application for continuous tracking data analysis as per work of Wall *et al.* (2014). Also the study highlight future directions of real-time collection and analysis of biological, physiological and environmental information from wildlife to encourage further development of needed algorithms and monitoring technology. Real-time processing of remotely collected, animal bio spatial data promises to open innovative directions in ecological research, applied species monitoring, conservation programmes, and public outreach and education (Wittemyer *et al.*, 2014).

## **5.2 Related Works**

### **5.1.1 Rhino Security, Monitoring and Management System**

The Wireless Wildlife Rhino system was designed to enable the rhino owner to protect, manage and monitor their investment in wildlife in real time, 24 hours per day and to assist in the conservation of the specie (Wireless-Wildlife, 2016). The system has a built-in alarm functionality that alerts the user as soon as the rhino shows any sign of abnormal behaviour or ventures out of pre-set geographical borders. The system was also designed for research application where the behavioural patterns of rhinos can be monitored. Data such as activity, location, speed, velocity, direction of movement and temperature are stored and can be downloaded for these purposes. The system was designed to accommodate the private owner, wildlife institutes as well as research organizations (wireless-wildlife, 2006).

The system consists of 2 parts. The first part is the GPS rhino monitoring device that is implanted inside the rhino horn. This device monitors the rhino and is in constant communication with a base station. The second part a mentioned is the base station that is set up in the roaming area of the rhino. This station generates the coverage on which the GPS rhino monitoring device operates. The GPS rhino monitoring device sends all alarms, notifications and data to the base station, which then distributes it to the user. The system coverage can be extended by a relay station which can be set up in another area and relays all data received from GPS rhino monitoring devices to the base station for distribution to the user (Wireless- Wildlife, 2016). Users will receive real time alarms by a form of SMS and missed calls and all data are made available through a secure web interface. Alarms will include abnormal rhino activity (chasing,

threatening, stationing for too long) or if the rhino moves into or out of a specified zone (breaking fence).

The same GPS rhino monitoring device that is used for security purposes is implemented for research applications. The system layout is used in the security system application can also be used for researchers to download and access behavioural data. Base stations can be established at strategic points in the research area and as soon as the rhino moves into coverage of the base station, the data will be downloaded to be accessed through a secure web interface. Alternatively, researchers can be supplied with a manual download console. This enables data to be downloaded from the rhino by means of a manual field download technique or by plane. Wireless Wildlife has had great success by downloading data by means of a model plane with a built-in manual download console (wireless-wildlife, 2016).

### **5.1.2 Tracking Real Time Monitoring**

Save The Elephant (STE) uses GPS-tracking equipment to understand elephant lives, decisions and needs (Save the Elephants, 2018). The equipment shows the GPS location of an elephant within seconds of it being recorded by the tracking collar. The GPS Information is transmitted using Satellite or cellular network (Save the Elephants, 2018). The equipment uses software algorithms for monitoring obtained elephant movement data and digest complex information. Once algorithm looks precisely for elephants that become abnormally immobile, a warning signal that can indicate that an elephant is in trouble will be sent (Save the Elephants, 2018). This system has been used for combating poaching activities. When poaching incident detected and is accurately identified by the system, a warning signal is sent via SMS and e-mail to wildlife officers and for response (Save The Elephants, 2018).

### **5.1.3 Design of Elephant Collars to Reduce Crop Foraging**

The damage caused by elephants can be catastrophic to local subsistence economies. Farmers suffer the brunt of damage, anxiety and frustration caused by elephants. Costs to the local communities include property damage, human injury or death, competition over water resources, social disruptions (Kangwana, 1995; Kiiru, 1995). The Western Kentucky Department of Engineering and the Department of Biology designed a deterrent system to help farmers while maintaining the integrity of the elephants' health and well-being (Hoare, 1996). This paper discusses the design of elephant collars used to determine if an elephant has entered an exclusion



zone. The elephant's location is determined using GPS. Collars will activate when collared elephants enter an exclusion zone in particular (World Wide Fund for Nature [WWF], 2018).

### **5.3 Existing System**

Most of the existing wildlife monitoring softwares in Tanzania National Parks are web based which normally uses personal computer terminal (PC). In the existing system the rangers cannot receive the monitoring information easily while in patrol.

### **5.4 Proposed System**

Android is mobile phone operating system based on Linux platform (Myeong *et al.*, 2011). In order to solve the limitations of traditional monitoring system, this research work proposed a monitoring scheme based on smart mobile phone. This system has made it possible to monitor sensors in real-time via smart phone under the coverage of wireless network (Abhishek & Shah, 2012). This research proposed a monitoring scheme prototype based on android smart phone terminal. The system work by gathering and processing data at a server and sending data to smart phone mobile terminal via web services (Fryxel *et al.*, 2008).

Global positioning system (GPS) tracking data, heart rate, temperature and horns synchronization signal are being collected using smart sensing collar developed by us. The sensors' responses are frequently sampled at 5sec intervals. Output responses from the sensors are transmitted via GSM network or Satellite Communication (Wall *et al.*, 2014).

The sensor data are received on a cloud-based server from a designed smart collar using either a direct connection (e.g., via Transport Control Protocol/Internet Protocol [TCP/IP]) or retrieval from application programming interface (API). The developed mobile application software handles data and stores it locally in a Postgre SQL database (Wall *et al.*, 2014). The custom-built movement monitor software monitors incoming data and implements each of the four GIS algorithms (proximity, geo-fencing, movement rate, immobility) on a continuous basis. Once a behavioral state of interest has been identified algorithmically, an alert is triggered and distributed using various dissemination methods that target the variety of users of the system including mobile application, e-mail and SMS.

### **5.5 Design**

Basic designs for smart sensing rhinos and elephants collar System were sketched to determine exact operations required for real time monitoring. Architecture Diagram and interface designs

of both desktop and android application were sketched (Fig. 22). Decisions were Android Development Kit, Desktop Application Platform and database servers to be used. Figure 22 depicts the Architecture diagram of smart sensing rhinos and elephants collar System.

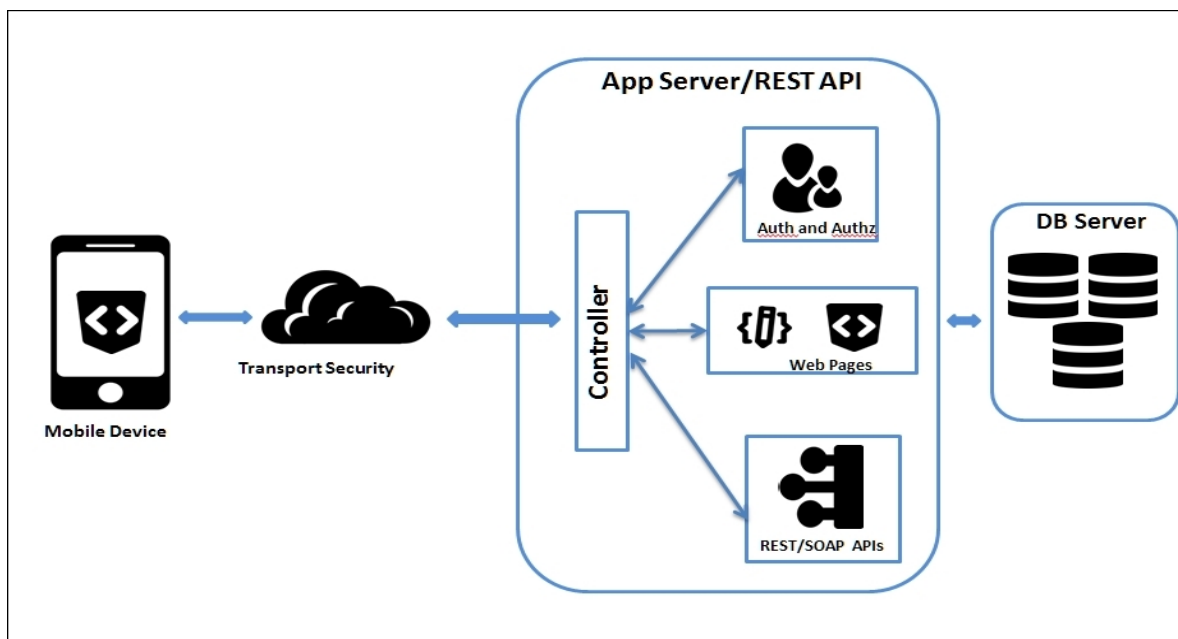

**Figure 22: Architecture Diagram**

Auth = Api verification for single request, Authz = Api verification for multiple request which belongs to login and database connection script. The REST Api = representational state transfer Access point interface.

### 5.5.1 Algorithm explanation

This algorithm describes the connectivity between http server client and app server. This connection takes place in step by step process (Wall *et al.*, 2014).

Step 1: The user has to enter his or her username and password.

Step 2: Once the details are entered a user has to hit the login button.

Step 3: The user's details will be checked from the server.

Step 4: Once the details prove true, the intent will pass from one activity to another.

### 5.5.2 Modules of proposed system

#### (i) Client Module

It defines the interaction between the user and the server by means of providing the authentication properties (Wall *et al.*, 2014).

**(ii) Server Module**

Authority module is the server module, which receives the sensors data and GPS locations from the animal and transmits it to the rangers, researchers and veterinarian access with optimal path information.

**(iii) Database connectivity module**

The capacity of this module is to maintain the details about the animal’s condition and process involved in tracking (Wall *et al.*, 2014).

**5.5.3 Component Diagram**

The diagram below (Fig. 23) describes the main application components of the emotional real-time monitoring mobile application software. The system comprises five application modules; ranger module, veterinarian module, researcher module, data base module and admin module. Data base module is used to store and organize sensor responses from other modules. Ranger modes, veterinarian and researcher modules are used to execute application functions of the system. Admin module is used to control all credentials of the user of the system.

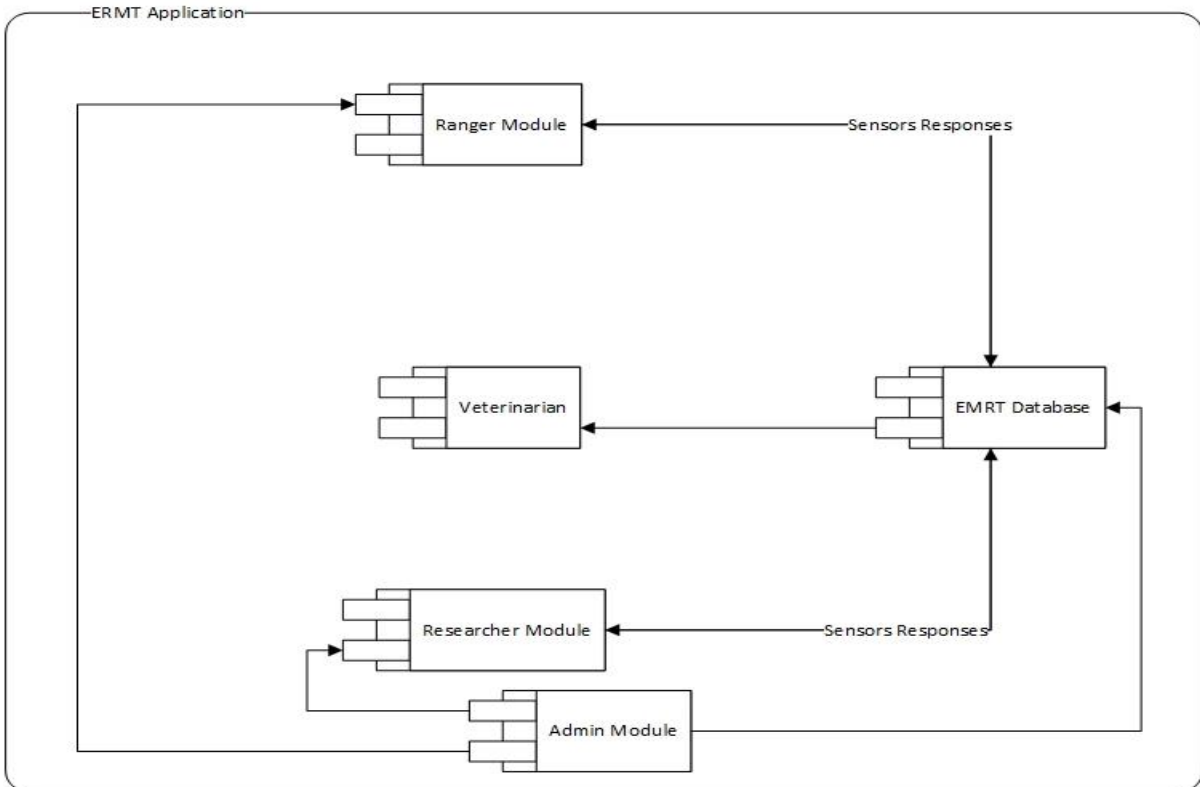

**Figure 23: Component diagram**

#### **5.5.4 Actor of Proposed System**

**(i) User**

User is an important actor, he/she sends the information about the bin status to the server proceeding the appropriate level. Before transmitting the information, a user must register with the system (Wall *et al.*, 2014).

**(ii) Authority**

Authority is a person who is monitoring the process of the animal condition via sensors and GPS location responses in the particular area. That person also must register with the system (Wall *et al.*, 2014).

**(iii) Rangers, researchers and Veterinarian**

Rangers, researchers and veterinarians are the persons are monitoring the process. They are responsible for taking action upon the data collected from the sensors' responses and GPS location. Figure 24 shows information flow among between the ERMT Mobile Application and Rangers, researchers and veterinarians.

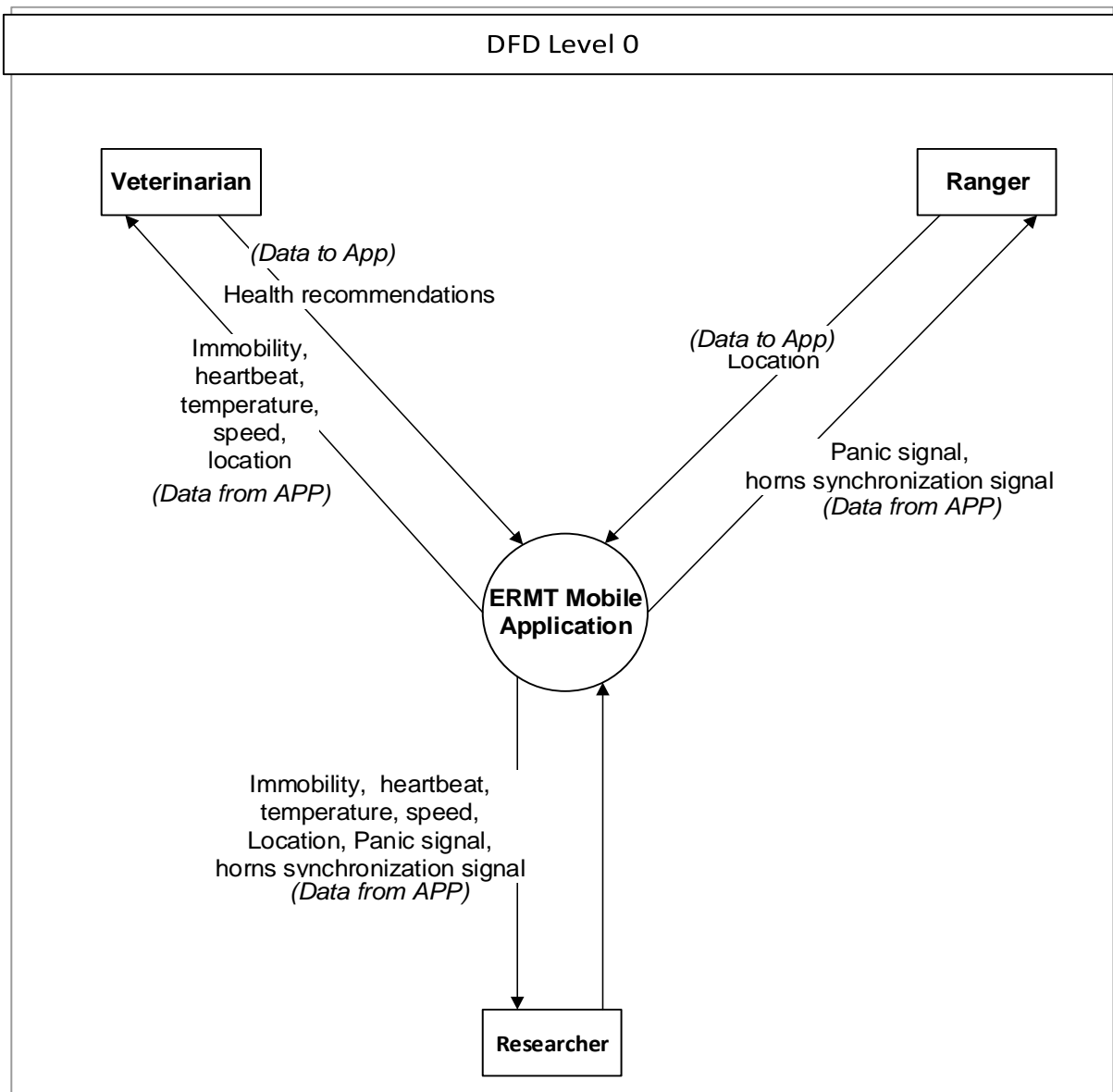

**Figure 24: Data Flow Diagram**

### 5.5.5 Implementation

Android Application, Desktop Application and Web Service were developed in parallel using Android Studio and Visual Studio respectively. Firebase Server has been used with Firebase Cloud Messaging (FCM) notification service to send necessary notifications to Android Application. C#.NET, Micro C, C, and JAVA were used as programming languages. Microsoft SQL Server 2008 R2 has been used to develop a database for Easy Clean System whereas Windows Communication Foundation (WCF) with restful services has been used to manipulate database content.

## **5.6 Testing**

The real-time monitoring system was tested by applying different test cases. Test cases were prepared to test each and every path available in the Desktop and Android application. Unit testing, integration testing and system testing were carried out to confirm system reliability. Different units of the system were tested separately in unit testing whereas Integration of all the units as a whole tested during integration and system testing. The animal collar belt was tested on dog as a pilot study for this research work.

## **5.7 Results and Discussions**

The important implications of the research findings, regardless of the statistical significance of this research are discussed below. Further, identifying the defect and limitation of this project can be useful for future researchers in order to conduct other researches. The major object of real time monitoring is to provide an efficient animal's information management system. Real time monitoring system comprises of three major components such as sensors and GPS location output responses, desktop application for the national park authority and Android application for rangers, researchers and veterinarians.

## **5.8 Android App Output**

The home screen of the Android application is shown in the Fig. 25. It consists of an optimized user interface for the easier access. Two login restrictions are used to verify the authorized users which are username and password.

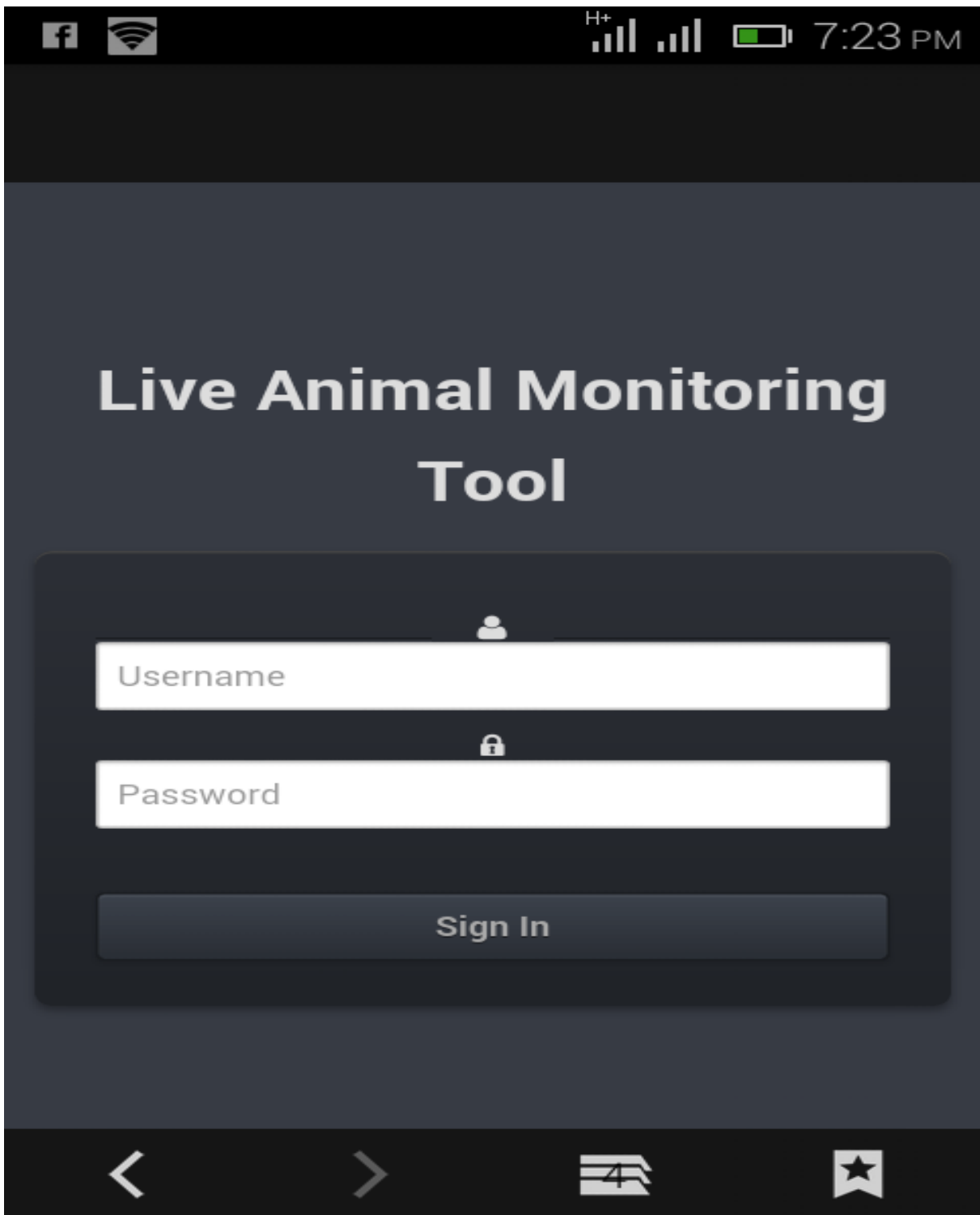

**Figure 25: Smart Sensing Animal Collar Belt Home Page of App**

Tapping the “sign in” button will land the user to the menu form as shown in the Fig. 26-28 it displays a chart which shows the sensors output responses.

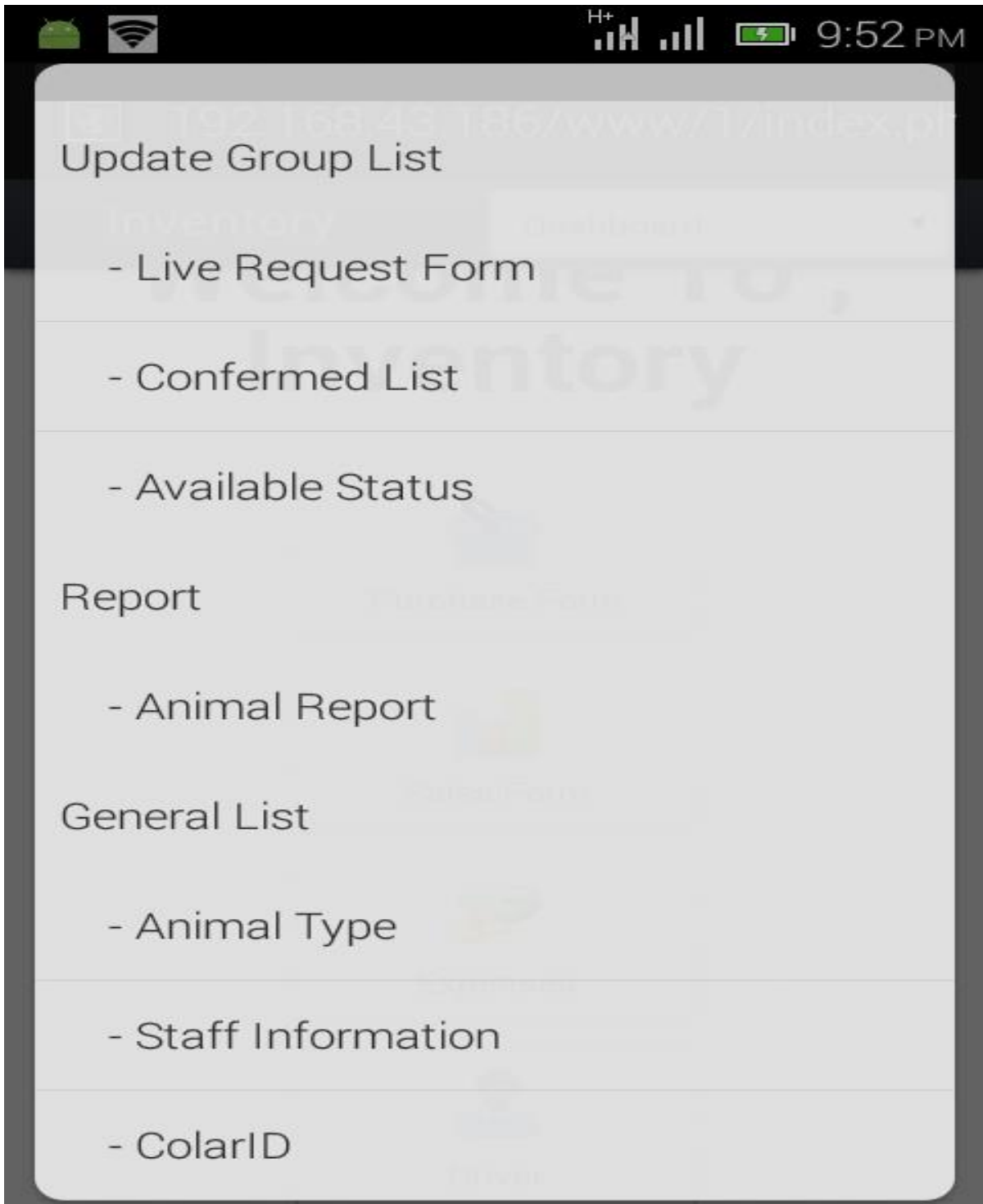

**Figure 26: System Menu**



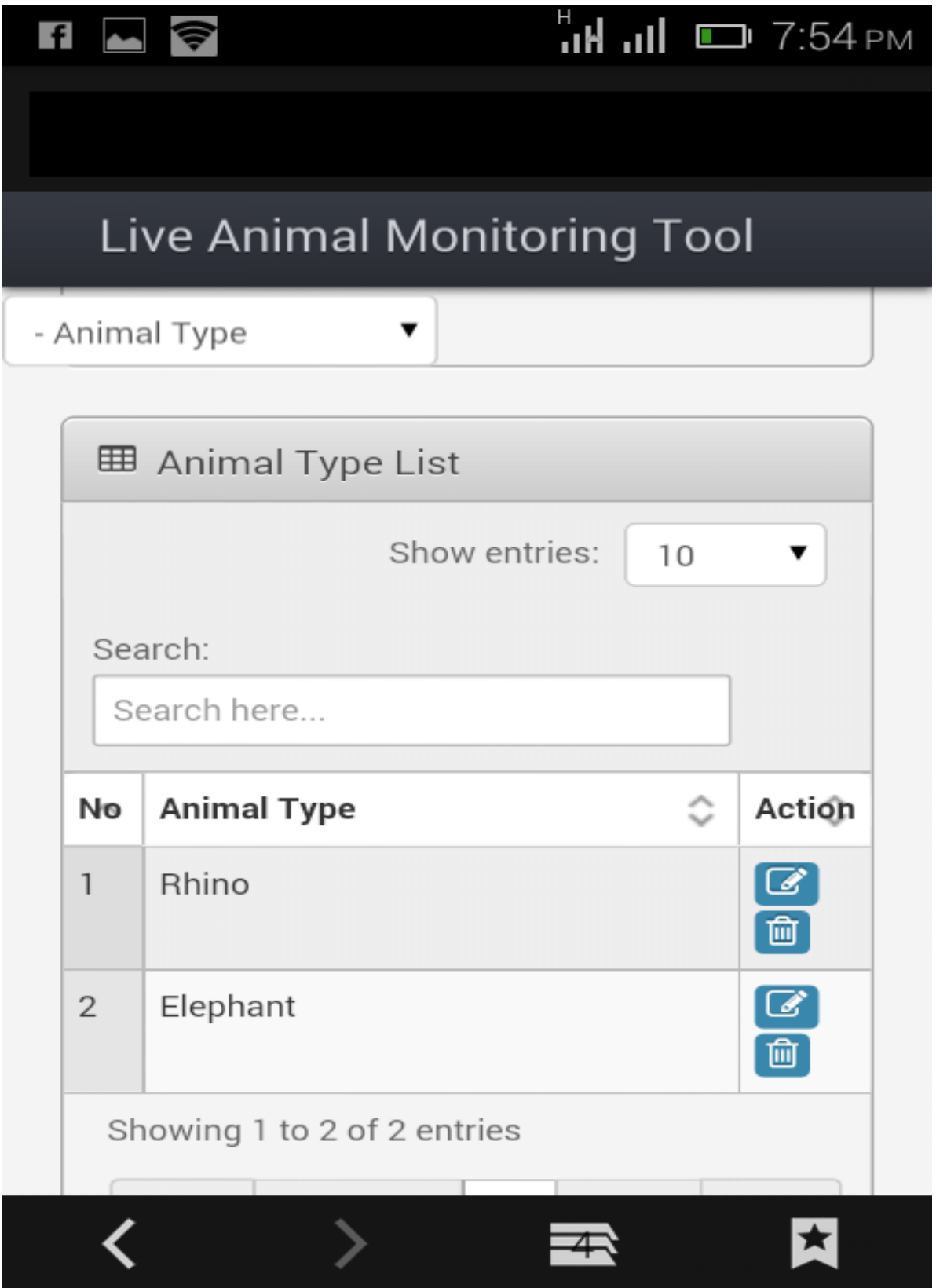
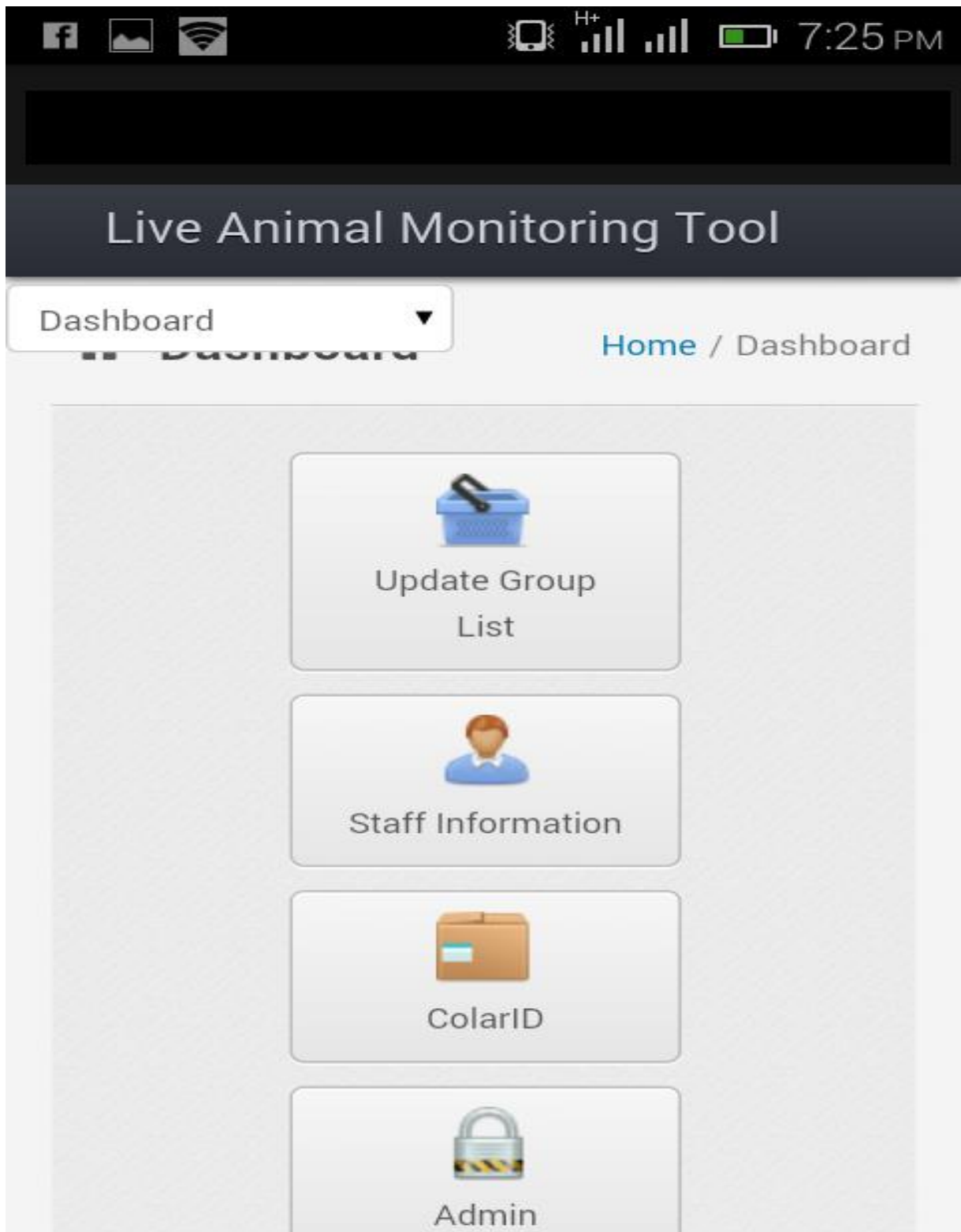

Figure 27: Animal Types



**Figure 28: Dashboard**

The sensors output readings and related details received from smart animal collar belt were manipulated in the main desktop application of the national park authority to ensure proper real-time management system. These sensors and GPS location status are also displayed in ranger/researcher/veterinarian mobile application.

Initially, the national park authority registers user categories (rangers, researchers and veterinarians).

### **5.8.1 Ranger**

This user category will be able to access mortality and location.

### **5.8.2 Veterinarian**

This user category will be able to access animal health related information and location.

### **5.8.3 Researcher**

Will be able to access all animal information tracked.

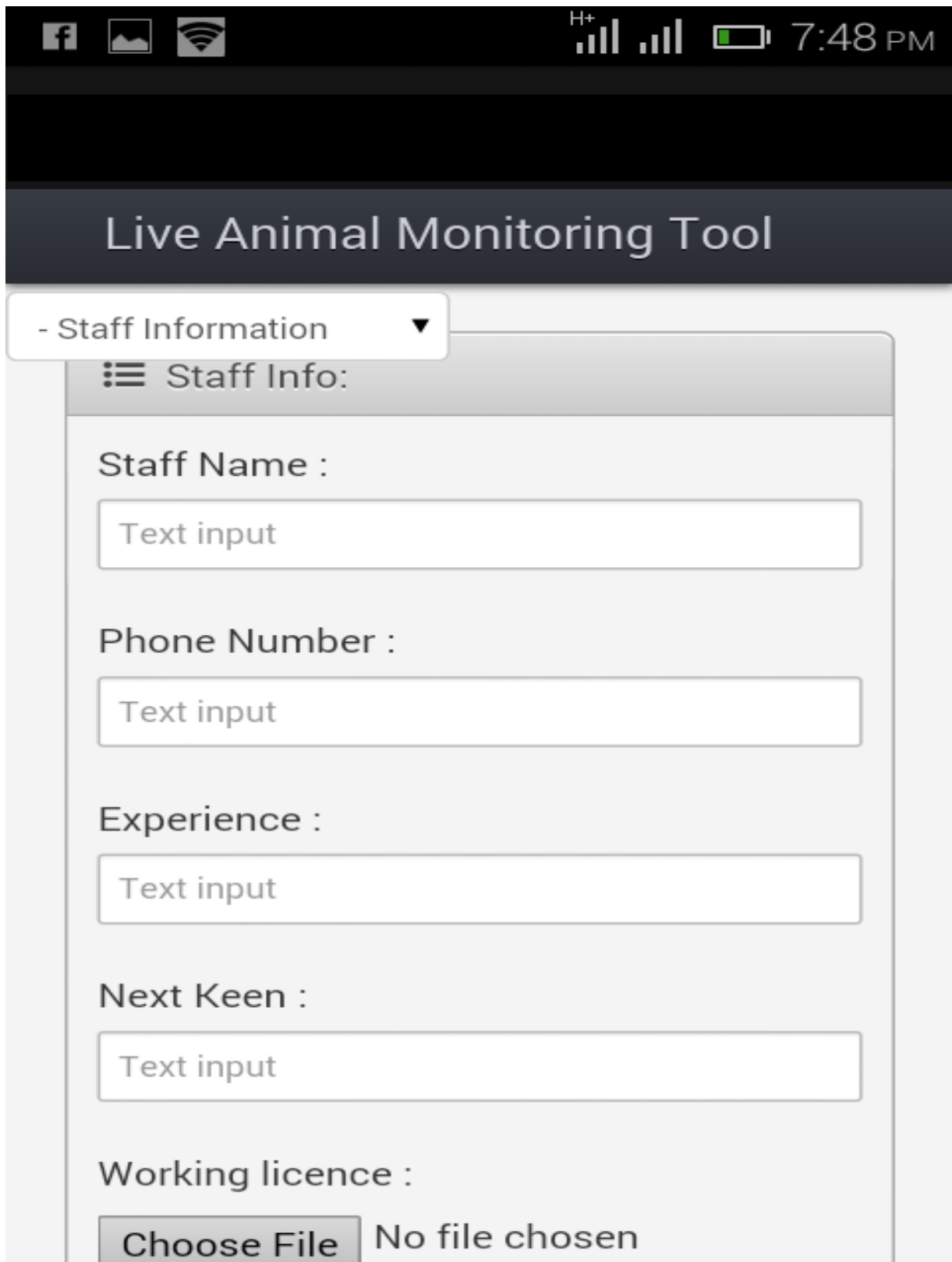

**Figure 29: System user's Registration**

Then national park authority carries monitoring process of the actions taken by the rangers upon panic signal sent from the smart sensing collar. Rangers in the patrolled areas will be automatically scheduled by the application. Figure 29 shows application interface relevant to this

scheduling process. Real-time monitoring about collections is achieved through Google map API embedded in the main desktop application. Then, the real-time navigation routes for responding to the poaching incident area is displayed to the ranger's vehicle using real time monitoring mobile application. The application interface used for monitoring purpose and navigation route maps is displayed to the ranger in the real time monitoring mobile application. Finally, whenever there is a panic alert the responsible ranger notifies it to the national park authority the time of attendance. Soon after each and every sensor response details are updated to the application. Figure 30 and 31 show application interfaces which display alert attended details and report generation, respectively.

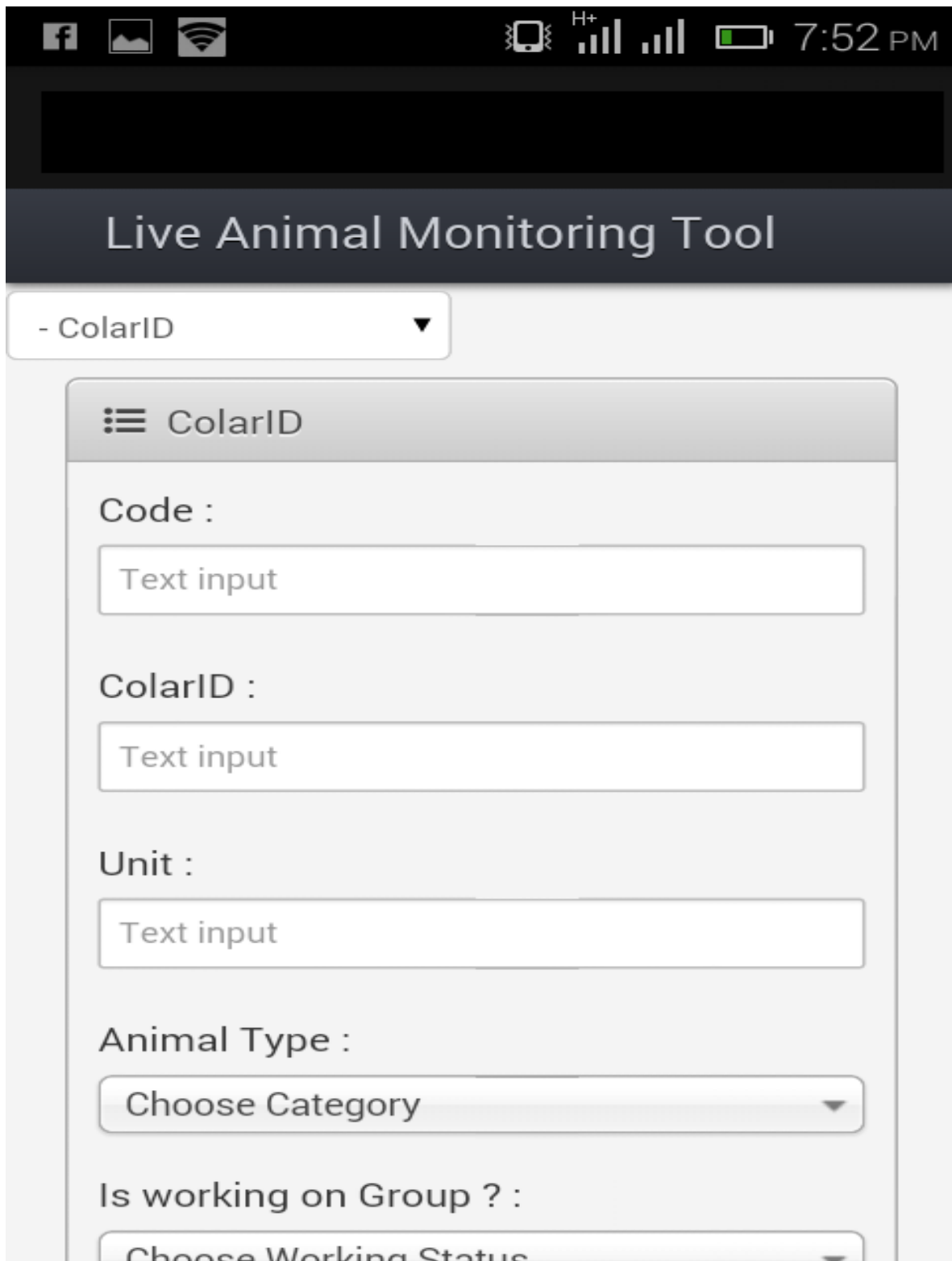

**Figure 30: Smart Sensing Collar Belt Details**

Reports regarding sensors' outputs are generated by the main desktop application as per user selections of administrative staff. Figure 31 below indicates the interface regarding report generation.

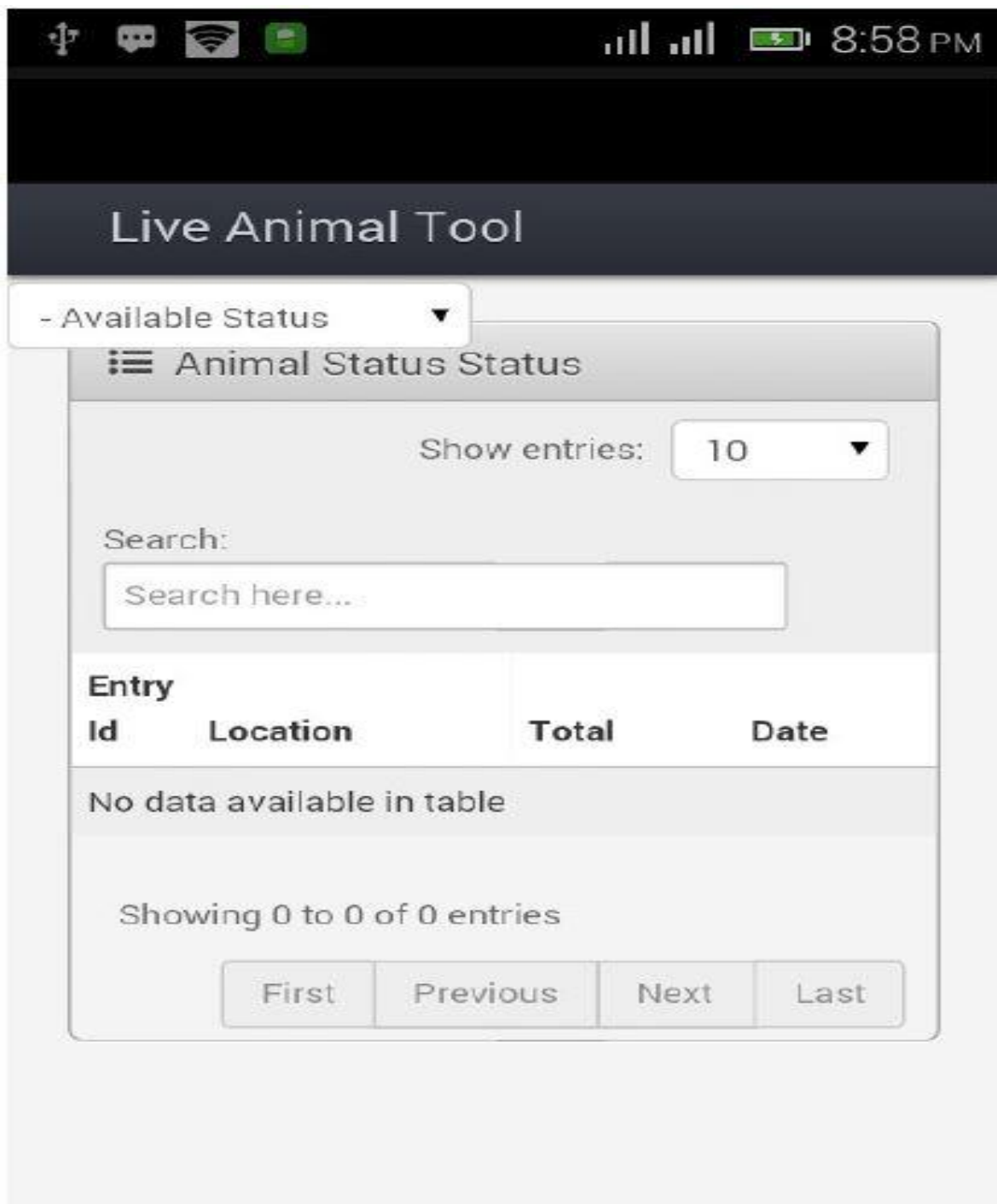

**Figure 31: Report Generation**

Monitoring of the sensors and GPS location in real time makes the system highly reliable. This real-time process has been achieved through secure real-time data transmission using WCF. Cost effective navigation maps and rangers' schedules in a user-friendly manner provide a reliable interface for immediate attendance to any poaching occurrence. Google Map Android API has been used to get cost effective routes to destinations (poaching areas). Authentication verification using username and password when accessing the desktop application and mobile application ensures security for basic authentication issues. Firebase tokenizing for each and every mobile

with elephant/rhino real-time monitoring Android App has been used to ensure that no user succeeds multiple accounts in multiple devices at the same time.

## **5.9 Conclusion and Recommendations**

The rhino/elephant real time monitoring tool will provide comprehensive solutions to poaching incidences. This mobile application could track status of the sensors on animal body and GPS location output responses. Rangers, researchers and veterinarians will be notified with the status of the animals through the mobile application. Reports related to the horns synchronization, proximity, geo-fencing, movement rate, and immobility could be generated through this system. Finally, the project successfully achieved to fulfil all the objectives of this system and hope this research would be of beneficial to many entities. The research team hopes that this study will be helpful for the researchers who are interested in the topic. It will also widen better understanding and knowledge to implement similar kind of projects or hi-technical projects with more advanced tools.

During the development of this project, the following are the limitations identified:

- (i) Need data plan enabled SIM; GSM/GPRS uses mobile SIM data to transfer real-time data of the animal smart collar status to the server. Therefore, data plan should be enabled in this case and recharging is needed to maintain an uninterrupted connection with the central MC server.
- (ii) Less accuracy with GPS location readings; location of the animal smart collar is being noted using GPS module which needs at least 3 satellite connections to accurately read a location. However, the location may be inaccurate in case of fewer satellite connections.
- (iii) Smartphone and basic knowledge are significant; various research paths would be open to the researchers in order to meet the objectives. This research has elevated modern technologies; project team has identified some immediate set of future works which may be of interest to the researchers in this area: (a) Integrating the real-time monitoring system at public level and providing platform for reporting any poaching incidence or provide information regarding elephants interactions/proximity to people settlements; (b) Developing the mobile application with multi-platform support and expand the system targeting wildlife management for the entire country national parks.



## CHAPTER SIX

### General Discussion, Conclusion and Recommendations

#### 6.1 General Discussion

The main goal of this research was to develop an intelligent real-time wireless sensor network tracking system for monitoring rhinos and elephants in Tanzania National Parks. To achieve this goal, four research questions were formulated along with their corresponding objectives. The research was mainly guided by a scientific design research approach where academic committees granted approval to conduct this research and a research permit was obtained from Tanzania Wildlife Research Institute (TAWIRI), Ngorongoro Conservation Area Authority (NCAA) and Tanzania Commission for Science and Technology (COSTECH).

To solve an integrated global STEM problem like poaching, it requires a creative educational framework that can guide in developing an efficient solution methodology. Design Thinking (Brown, 2008) is such an iterative problem-solving process of discovery, ideation and experimentation that employs various design-based techniques to gain insight and yield innovative solutions to real world challenges that focus on the needs of people as consumers, clients or ordinary citizens.

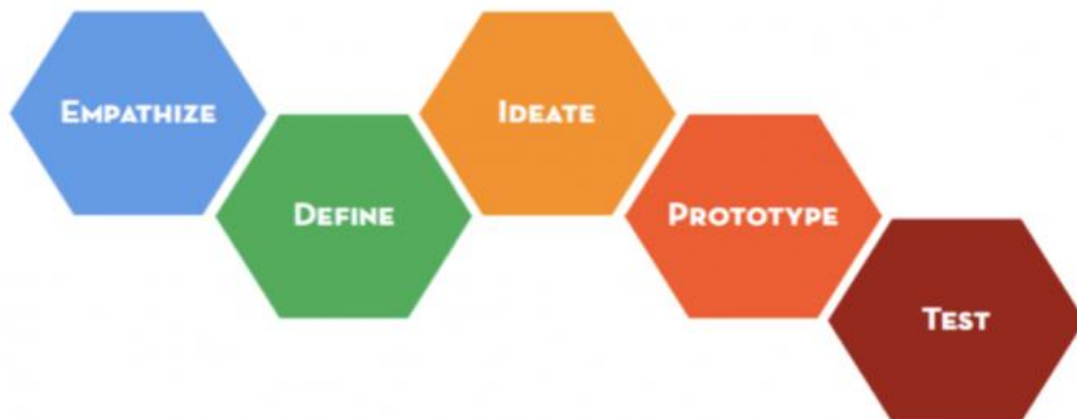

**Figure 32: Five Fundamental Steps in Design-Thinking**

Design thinking (Fig. 32) is a human-centred approach for developing innovative solutions to real-world problems such as poaching. Motivated by our project to stop poaching of elephant tusks and rhino horns, we conducted a design thinking study in Arusha, Tanzania in

collaboration with the Nelson Mandela African Institution of Science and Technology in summer 2015. This framework was employed to engage 40 participants including students, teachers, faculty and the broader community from various parts of Tanzania through a workshop that focused on Design Thinking, Innovation, Creativity and Entrepreneurship (DICE). Specifically, we helped providing the participants with exposure to design thinking, problem-based learning, collaborative innovation, design-based engineering techniques, and inquiry-based scientific innovation. We had the opportunity to develop prototypes and shared feedback from the participants. We also worked on collaborative projects that helped to understand three important phases of any project including discovery phase for insights generation, the design phase for concept generation, and the delivery phase for prototyping and testing. The responses from the participants helped to guide responses to our research questions.

In order to answer the first research question, primary data were collected in a one multi cross-sectional study. In addition, comprehensive review on the current situation and historical approaches on ant-poaching systems was undertaken. The second research question was answered by designing, coding and prototyping a collar belt for collecting data from the dog as a pilot study. The collected data were coded and analyzed by using MATLAB software. The third research question was answered by computing wireless sensor network attenuation models for minimization of wireless interference. The fourth research question was answered by development of Android mobile application for wildlife conservation and research information management with real-time monitoring. Research findings and experimental results were published in International Journal of Advanced Smart Sensor Network Systems and International Journal of Computer Applications.

In Chapter one, the background and motivation for the research problem were explored. Literature concerning basic concept in ant-poaching systems and ongoing researches was discussed. Findings revealed that many systems have been developed, but with different engineering trade-offs that meet only the needs of domestic animal applications. However, there is no testified designed, intelligent system that can monitor rhinos and elephants at the panic stage before being killed by the poachers.

In Chapter two, a narrative review on ant-poaching systems was explored; theories and practice in intelligent systems were studied extensively. The literature concerning intelligent real-time monitoring systems was reviewed. A comparative analysis of the mostly used approaches in real-time monitoring systems was conducted. The ant-poaching system used

by World Elephant Centre (WEC) in Tanzania was also reviewed and participated on Ruaha National Park and Rungwa Game Reserve elephants collaring project on where 30 elephants were collared to monitor their behaviour, movement and any conflict with human communities. Also, we conducted research findings at Ngorongoro Conservation Area and reviewed two systems which they are used for monitoring rhinos. Findings discovered that intelligent real-time ant-poaching system is not much explored. Also, the findings revealed that the current used systems are expensive and were not built for poaching prevention purposes.

In Chapter three, designing of the advanced animal collar belt that can detect animal emotion using various sensors attached on it was successfully achieved. Pilot study testing of the system on a dog was conducted. The results were coded and analyzed in graphical form using MATLAB software. Findings revealed that measurement of animal body physiological parameters can lead on prediction of animal emotion state. Also, synchronization of the rhinos/elephants' horns will contribute much on the monitoring process. The output data from the sensors will also be used by veterinarians and researchers for ecological monitoring and wildlife conservation based on proximity, geo-fencing, movement rate, and immobility of the rhinos/elephants.

*In Chapter four*, it was found that wildlife tracking solution in Ngorongoro Conservation Area as the case study of this research has unique engineering, design and technology challenges. A number of blocks are involved and all need to be considered for an optimal tracking network particularly in relation to signal transmission and reception. Wireless communications typically are based on radio frequency signals that require a clear and unobstructed transmission path; and so, the goal during design was to get as close to such an ideal transmission path as possible. Using ITU models the area was analyzed and predictions for the factors that should be considered for network optimality were exposed.

Finally, in Chapter five, the main concern is user interface real-time monitoring system that can be capable of disseminating biological, physiological, and environmental information of rhinos and elephants periodically. Android mobile application platform was developed successfully and tested on our pilot study.

## **6.2 Conclusion**

The goal of this research work was to develop an intelligent real-time wireless sensor network tracking system for monitoring rhinos and elephants in Tanzania national parks. To achieve this

goal four studies were formulated to cover the research topic. The research based on system design, where a dog was selected for pilot study and Ngorongoro Conservation Area as a case study. It is concluded that real-time wireless sensor network anti-poaching systems research requires sensitive guaranteeing of immediate transfer of early warning panic signal to the rangers and conservations authorities for action.

### **6.3 Recommendations**

The following are recommended for future works:

- (i) More physiological parameters should be measured using appropriate sensors, only few parameters were measured in this research, therefore a further research is needed to compare the effective contribution of the other unmeasured physiological parameters towards animal emotional detection.
- (ii) The architecture proposed in Chapter 2 may further need improvement in topology for data transition on the sensors.
- (iii) Due to the existing confrontation on poaching, security of the ant-poaching sensor network is a key objective. Therefore, a further research is required to provide more secured security algorithms.
- (iv) The monitoring nodes proposed in Chapter 2, includes drones require another research on designing an algorithm for synchronization of automated drone with animal emotions detection sensor network for immediate action on animal poaching incidences.

## REFERENCES

- Abhishek, B. P. S. (2012). *Android based Remote Monitoring System: International Conference in Recent Trends in Information Technology and Computer Science*. <https://research.ijcaonline.org/icrtitcs2012/number2/icrtitcs1329.pdf>
- Al-Nuamin, M. O., & Hammoudeh, A. M. (1993). *Measurements and predictions of attenuation and scatter of microwave signals by trees*. [https://digital-library.theiet.org/content/journals/10.1049/ip-map\\_19949840](https://digital-library.theiet.org/content/journals/10.1049/ip-map_19949840)
- Alphonse, M., Kisangiri, M., Kaijage, S., & Sesaiyer, P. (2017). An intelligent real-time wireless sensor network tracking system for monitoring rhinos and elephants in Tanzania national parks. *International Journal of Advanced Smart Sensor Network Systems*, 7(4), 1-11.
- Bagree, R., Jain, V. R., Kumar, A., & Ranjan, P. (2010) TigerCENSE: Wireless Image Sensor Network to Monitor Tiger Movement. In P. J. Marron, T. Voigt, P. Corke, L. Mottola (eds), *Real-World Wireless Sensor Networks*. [https://doi.org/10.1007/978-3-642-17520-6\\_2](https://doi.org/10.1007/978-3-642-17520-6_2)
- Balcombe, J. (2015). *Learn how Cows Express their Emotions*. <http://www.humanesociety.org/news/magazines/2015/11-12/how-cows-express-emotions.html?referrer=https://www.google.com/>.
- Bank, W. (2004). *State-society Synergy for Accountability; Lesson for the World Bank (Working Paper no. 30)*. <https://elibrary.worldbank.org/doi/abs/10.1596/978-0-8213-5831-3>
- Banzi, J. F. (2014). A Sensor Based Anti-Poaching System in Tanzania National Parks. *International Journal of Scientific and Research Publications*, 4(4), 2250-3153.
- Barth, A. T., Hanson, M. A., Powell, H. C., & Lach, J. (2009). *TEMPO 3.1: A Body Area Sensor Network Platform for Continuous Movement Assessment: Sixth International Workshop on Wearable and Implantable Body Sensor Networks (pp.71-76)*. Berkeley, CA, USA. doi: 10.1109/BSN.2009.39.
- Blaunstein, N., Censor, D., & Katz, D. (2003). Radio Propagation in Rural Residential Areas with Vegetation. *Electromagnetics Research*, 40, 131–153.

- Blaunstein, N., Kovacs, I., Ben-Shimol, Y., Andersen, J., Katz, D., Eggers, P., Giladi, R., & Olesen, K. (2003). Prediction of UHF path loss for forest environments. *Radio Science*, 38(3), 1-25. 10.1029/2002RS002600.
- Bradley, M. M., & Lang, P. J. (1999). Fearfulness and Affective Evaluations of Pictures. *Motivation and Emotion*, 23, 1–13. <https://doi.org/10.1023/A:1021375216854>
- Brett, R. (2001). *Investigation of Black Rhino Mortalities at Ngorongoro crater, Tanzania: Black Rhino Habitat and Ecological Requirements, SADC Regional Programme for Rhino Conservation*. [http://www.rhinoresourcecenter.com/pdf\\_files/119/1196847969.pdf](http://www.rhinoresourcecenter.com/pdf_files/119/1196847969.pdf)
- Brett, R. (2001). *Investigation of black rhino mortalities at Ngorongoro Crater, Tanzania: Black rhino habitat and ecological requirements*. [http://www.rhinoresourcecenter.com/index.php?s=1&act=refs&CODE=ref\\_detail&id=1196797869](http://www.rhinoresourcecenter.com/index.php?s=1&act=refs&CODE=ref_detail&id=1196797869)
- Bristol, U. O. (2010). *Dogs May be Pessimistic Too*. <http://www.bris.ac.uk/news/2010/7261.html>.
- Brown, T. (2008). *Design Thinking*. Harvard business review. 86. 84-92, 141. <https://hbr.org/2008/06/design-thinking>
- Cavalcante, G. P. S, Sanches, M. A. R, & Oliveira R. A. N. (1999). Mobile radio propagation along mixed paths in forest environment. *Journal of Microwaves and Optoelectronics*, 1(4), 42-52.
- Cavalcante, S., Protásio, G., Rogers, A. D., & Giarola, J. A. (1983). Radio loss in forests using a model with four layered media. *Radio Science*, 18(5), 691-695. <https://doi.org/10.1029/RS018i005p00691>
- Chebil, J., Lawas, K. A., & Rafiqul, I. M. D. (2013). Comparison between Measured and Predicted Path Loss for Mobile Communication in Malaysia. *World Applied Sciences Journal*, 21, 123-128.
- Chen, Y., & Wang, X. (2008). *Design of Distributed Intelligent Physiological Parameter Monitor System Based on Wireless Communication Technology: International Seminar on Future BioMedical Information Engineering (pp. 403-406)*. doi: 10.1109/FBIE.2008.60.

- Choi, J. S., & Zhou, M. (2010). Recent advances in wireless sensor networks for health monitoring. *International Journal of Intelligent Control and System*, 14(4), 49-58.
- Conti, M., Dipietro, R., Vincenzo, L., & Alessandro, M. (2008). *Emergent properties: Detection of the node-capture attack in mobile wireless sensor networks. Proceedings of the first ACM conference on Wireless network security March 2008 (pp. 214–219).* <https://doi.org/10.1145/1352533.1352568>
- David, N., Kamarudin, L., Mohammad, E., Ammar, Z., Ahmad, R., Fareq, M., Shakaff, A., & Jafaar, M. (2012). Vegetation attenuation measurements and modeling in plantations for wireless sensor network planning. *Electromagnetics Research*, 36, 283-301. Doi 10.2528/PIERB1109190.
- Deepak, G., Alberto, C., Wei, Y., Yan, Y., Jerry, Z., & Deborah, E. (2004). Networking Issues in Wireless Sensor Networks. *Journal of Parallel and Distributed Computing*, 64(7), 799-814.
- Didascalou, D., Younis, M., & Wiesbeck, W. (2000). Millimeter-wave scattering and penetration in isolated vegetation structures. *Geoscience and Remote Sensing*, 38, 2106 - 2113. 10.1109/36.868869.
- Donatus, G., Wilfred, G. W. E., & Odadi, O. (2016). Spatial-temporal distribution of the black rhino population in the Ngorongoro Crater, Tanzania. *International Journal of Biological Research*, 4(2), 232-236.
- Egli, J. (1957). *Radio Propagation above 40 MC Over Irregular Terrain*. Vehicular Technology, New York. [https:// www. scirp. org/ \(S\(oyulxb452alnt1aej1nfow45\)\)/ reference /ReferencesPapers. asp?ReferenceID=1840697](https://www.scirp.org/(S(oyulxb452alnt1aej1nfow45))/reference/ReferencesPapers.aspx?ReferenceID=1840697)
- Elson, J., & Estrin, D. (2004) Sensor Networks: A Bridge to the Physical World. In C. S. Raghavendra, K. M. Sivalingam, T. Znati (eds), *Wireless Sensor Networks*. Springer, Boston, MA. [https://doi.org/10.1007/978-1-4020-7884-2\\_1](https://doi.org/10.1007/978-1-4020-7884-2_1)
- Estrin, D., Culler, D., Pister, K., & Sukhumi, G. (2002). Connecting the physical world with pervasive networks. *Journal of Pervasive Computing*, 1(1), 59-69. doi: 10.1109/MPRV.2002.993145.

- Fernandez, G. A. J., Sanchez, G. M., Cuinas, I., Alejos, V. A., Sanchez, G. J., & Jose-Sierra, M. L. J., (2010). Propagation Analysis and Deployment of a Wireless Sensor Network in a Forest. *Electromagnetics Research*, 106, 121-145. doi:10.2528/PIER10040806
- Foldy, L. L. (1945). The Multiple Scattering of Waves. I. General Theory of Isotropic Scattering by Randomly Distributed Scatterers. *Physical Review*, 67 (3-4), 107-119. <https://link.aps.org/doi/10.1103/PhysRev.67.107>
- Frankfurt Zoological Society. (2003). *Annual Report*. [https:// www. Poverty and conservation. info/ en/ org/o0434](https://www.Povertyandconservation.info/en/org/o0434)
- Gadiye, D. E., & Koskei, A. (2016). Spatial-temporal distribution of the black rhino population in the Ngorongoro Crater, Tanzania. *International Journal of Biological Research*, 4(2), 232-236.
- Ganqa, N. M., Scogings, P. F., & Raats, J. G. (2005). Diet selection and forage quality factors affecting woody plant selection by black rhinoceros in the Great Fish River Reserve, South Africa. *South African Journal of Wildlife Research*, 35, 77–83.
- Gaworecki, M. (2017). *Mongabay: Cash for conservation: Do payments for ecosystem services work?* Retrieved from <https://news.mongabay.com/2017/10/cash-for-conservation-do-payments-for-ecosystems-services-work/>.
- Gomes, R. S., Gallardo, T., Fernández, J. A., & Adrián, B. (2005). On the Origin of The High-Perihelion Scattered Disk: The Role of The Kozai Mechanism and Mean Motion Resonances. *Celestial Mechanics and Dynamical Astronomy*, 91, 109–129. <https://doi.org/10.1007/s10569-004-4623-y>
- Guironnet, M., Guyader, N., Pellerin, D., & Ladret, P. (2005). *Spatio-temporal attention model for video content analysis: International Conference on Image Processing*. Genova, Italy. doi: 10.1109/ICIP.2005.1530602. <https://ieeexplore.ieee.org/abstract/document/1530602>
- Guldmond, R., & Van Aarde, R. (2007). The impact of elephants on plants and their community variables in South Africa's Maputaland. *African Journal of Ecology*, 45, 327-335. 10.1111/j.1365-2028.2007.00714. x.



- Haag, A., Goronzy, S., Schaich, P., Williams, J. (2004). Emotion Recognition Using Biosensors: First Steps towards an Automatic System. In E. André, L. Dybkjær, W. Minker, P. Heisterkamp (eds), *Affective Dialogue Systems*. [https://doi.org/10.1007/978-3-540-24842-2\\_4](https://doi.org/10.1007/978-3-540-24842-2_4)
- Hamilton, J., Maddison, D., & Tol, R. (2005). Effects of climate change on international tourism. *Climate Research*, 29(3), 245-254.
- Hammoudeh, A., Stephens, R., & Al-Nuaimi, M. (1996). *Characterisation and modelling of scatter, attenuation and depolarisation of millimetre waves due to foliage: The 26<sup>th</sup> European Microwave Conference*. <https://ieeexplore.ieee.org/document/4138774>
- Hoare, R. E. (1996). Determinants of human–elephant conflict in a land-use mosaic. *Journal of Applied Ecology*, 36(5), 689-700.
- Horn, R. A., & Johnson, C. R. (1985). *Matrix Analysis*. Cambridge University Press. [www.cse.zju.edu.cn/eclass/attachments](http://www.cse.zju.edu.cn/eclass/attachments)
- Hum, V. S. (2017). *Radio and Microwave Wireless Systems*. <https://www.coursehero.com/file/p2mkj5oh/Prof-Sean-Victor-Hum-ECE422-Radio-and-Microwave-Wireless-Systems-Atmospheric/>
- International Conference in Recent Trends in Information Technology and Computer Science. (2012). *Android based Remote Monitoring System*. New Panvel. <https://research.ijcaonline.org/icrtitcs2012/number2/icrtitcs1329.pdf>
- International Conservation Caucus Foundation. (2013). *The African Poaching Crisis*. [http://iccfoundation.us/index.php?option=com\\_content&view=article&id=445&Itemid=367](http://iccfoundation.us/index.php?option=com_content&view=article&id=445&Itemid=367).
- International Radio Consultative Committee. (1986). *Influences of terrain irregularities and vegetation on troposphere propagation (CCIR- Report 235-236)*. Geneva. [search.itu.int/history/4.282.43.en.1006.pdf](http://search.itu.int/history/4.282.43.en.1006.pdf)
- International Telecommunication Union. (1999). *Recommendation ITU-R P.530-8, Propagation data and prediction methods required for the design of terrestrial line-of-sight systems*. Geneva. [www.itu.int/rec/R-REC-P.530](http://www.itu.int/rec/R-REC-P.530)

- International Telecommunication Union. (2012). *Attenuation in Vegetation. ITU-R Recommendation 833-7*. Geneva. [www.itu.int](http://www.itu.int) › [dms\\_pubrec](#) › [itu-r](#) › [rec](#)
- International Telecommunication Union. (2015). *Prediction Procedure for the Evaluation of Interference Between Stations on the Surface of the Earth at Frequencies Above about 0.1 GHz*. <https://www.itu.int> › [dms\\_pubrec](#) › [itu-r](#) ›
- Ishimaru, A. (1997). *Wave Propagation and Scattering in Random Media*. [https:// www.semanticscholar.org/ paper/ Wave -propagation -and -scattering -in -random -media-Ishimaru/ 4529dbc8562cde29684d13c64d101587d08700de?p2df](https://www.semanticscholar.org/paper/Wave-propagation-and-scattering-in-random-media-Ishimaru/4529dbc8562cde29684d13c64d101587d08700de?p2df)
- ITU. (2004). *ITU-R Recommendation*. [https:// emfguide. itu. int/ pdfs/ T-REC-K. 52-200412.pdf](https://emfguide.itu.int/pdfs/T-REC-K.52-200412.pdf)
- ITU. (2012). Attenuation in vegetation Recommendation ITU-R: 833-837. [https:// www. Itu .int/ rec/ R-REC-P.833-7-201202-S/en](https://www.itu.int/rec/R-REC-P.833-7-201202-S/en)
- ITU-TU-R. (2000). *Recommendation 527-523, 1978-1982-1990-1992-2000*. <https://emfguide.itu.int/pdfs/T-REC-K.52-200412.pdf>
- Iwendi, C., Allen, A., & Ofor, K. (2015). Smart security implementation for wireless sensor network nodes, *Wireless sensor network*, (1), 1–13.
- Jensen, M. B., Vestergaard, K. S., & Krohn, C. C. (1998). Play behaviour in dairy calves kept in pens: The effect of social contact and space allowance. *Applied Animal Behaviour Science*, 56, 97-108.
- John, M., Fryxell, M. H., Luca, B., Ben, D. D., Daniel, T. H., Juan, M. M., Therese, M., & Rick, C. R. (2008). Multiple movement modes by large herbivores at multiple spatiotemporal scales. *Proceedings of the National Academy of Sciences*, 105 (49) 19114-19119; DOI: 10.1073/pnas.0801737105 [https:// www. pnas. org/ content/ 05/ 49/ 19114/](https://www.pnas.org/content/05/49/19114/)
- Johnson, R. A., & Schwering, F. (1985). *A Transport Theory of Millimeter Wave Propagation in Woods and Forests (Technical report. Jul 1982-Jul 1984)*. [https:// apps. dtic. mil/ sti/ citations/ ADA151883](https://apps.dtic.mil/sti/citations/ADA151883)
- Juang, P., Oki, H., Wang, Y., Martonosi, M., Peh, L. S., & Rubenstein, S. D. (2002). *Energy-efficient computing for wildlife tracking: Design tradeoffs and early experiences with*

- ZebraNet. Proceedings of the 10<sup>th</sup> International Conference on Architectural Support for Programming Languages and Operating Systems (PP. 96–107).* <https://doi.org/10.1145/605397.605408>
- Kangwana, K. (1995). Human-elephant conflict: The challenge ahead. *Pachyderm*, 19, 11-14.
- Kasampalis, S., Lazaridis, P., Zaharis, Z., Bizopoulos, A., Zettas, S., & Cosmas, J. (2013). *Comparison of ITM and ITWOM propagation models for DVB-T coverage prediction. IEEE International Symposium on Broadband Multimedia Systems and Broadcasting. BMSB.* 10.1109/BMSB.2013.6621780.
- Kiiru, W. (1995). The current status of human-elephant conflict in Kenya. *Pachyderm*, 19, 15-19.
- Kikoti, D. A. (2017). *Where are the elephants corridors and other wildlife crossings in northern Tanzania? World Elephant Centre 20.* <https://link.springer.com/article/10.1007%2Fs10980-018-0728-7>
- Kikoti, P. A. (2009). *Seasonal Home Range Sizes, Transboundary Movements and Conservation of Elephants in Northern Tanzania. [Dissertation Submitted to the Graduate School of the University of Massachusetts Amherst in partial fulfillment of the requirements for the degree of doctor of philosophy].* University of Massachusetts Amherst. [https://scholarworks.umass.edu/cgi/viewcontent.cgi?article=1104&context=open\\_access\\_dissertations](https://scholarworks.umass.edu/cgi/viewcontent.cgi?article=1104&context=open_access_dissertations)
- Koh, I. S., Wang, F., & Sarabandi, K. (2003). Estimation of coherent field attenuation through dense foliage including multiple scattering. *Geoscience and Remote Sensing*, 41, 1132-1135. 10.1109/TGRS.2003.813552.
- Kunth, D., Leitherer, C., Mas-Hesse, J. M., Ostlin, G., & Petrosian, A. (2003). *The First Deep ACS Lyman alpha Images of Local Starburst Galaxies.*
- Lagrone, A. (1977). Propagation of VHF and UHF electromagnetic waves over a grove of trees in full leaf. *Transactions on Antennas and Propagation*, 25(6). 866-869. doi: 10.1109/TAP.1977.1141708. <https://ieeexplore.ieee.org/abstract/document/1141708>

- Landman, M., Schoeman, D. S., & Kerley, G. I. (2013). Shift in black rhinoceros' diet in the presence of elephant: Evidence for competition. *PloS One*, 8(7), e69771. <https://doi.org/10.1371/journal.pone.0069771>
- Lang, P. J., Bradley, M. M., & Cuthbert, B. N. (1999). *International affective picture system (IAPS): Instruction manual and affective ratings (Technical Report A-6)*. [https://scholar.google.com/scholar?cites=14019685485118300555&as\\_sdt=2005&scioldt=0,5&hl=en](https://scholar.google.com/scholar?cites=14019685485118300555&as_sdt=2005&scioldt=0,5&hl=en)
- Le-Wei, L., Tat-Soon, Y., Pang-Shyan, K., & Mook-Seng, L. (1998). Radio wave propagation along mixed paths through a four-layered model of rain forest: an analytic approach. *Transactions on Antennas and Propagation*, 46(7), 1098-1111. doi: 10.1109/8.704814.
- Mackay, D. (1992). The Evidence Framework Applied to Classification Networks. *Neural Computation*, 4, 720-736.
- Margarita, M. P., Zma'ny, R. S., Van Essen, L. D., Juan, J. N., & Tyrell, S. (2014). Remotely Piloted Aircraft Systems as a Rhinoceros Anti-Poaching Tool in Africa. *Plos One*, 9, 1-10.
- Matschek, R., Linot, B., & Sizun, H. (1999). *Model for wave propagation in presence of vegetation based on the UTD associating transmitted and lateral waves: National Conference on Antennas and Propagation (pp. 120-123)*. York. doi: 10.1049/cp:19990029. <https://ieeexplore.ieee.org/abstract/document/788851>
- Matthews, W., Shillito, L. M., & Elliott, S. (2013). Investigating Early Neolithic materials, ecology and sedentism: Micromorphology and microstratigraphy. In: Matthews, R. J., Matthews, W., & Mohammadifar, Y (eds), *The Earliest Neolithic of Iran: The Central Zagros Archaeological Project 2008 Excavations at Sheikh-e Abad and Jani*. Oxford: Oxbow Books and British Institute of Persian Studies. [https://www.researchgate.net/publication/271445207\\_Neolithic\\_Lifeways\\_Microstratigraphic\\_Traces\\_within\\_Houses\\_Animal\\_Pens\\_and\\_Settlements](https://www.researchgate.net/publication/271445207_Neolithic_Lifeways_Microstratigraphic_Traces_within_Houses_Animal_Pens_and_Settlements)
- Meng, J., & Skadron, K. (2009). *Performance modeling and automaticghostzone optimization for iterative stencil loops on GPUs. In Proceedings of the 23<sup>rd</sup> Annual ACM International Conference on Supercomputing*. <https://dl.acm.org/doi/abs/10.1145/1542275.1542313>

- Meng, J., Shuai, C., Michael B., David, T., Jeremy, W., Sheaffer, Sang-Ha, L., & Kevin, S. (2009). *Rodinia: A benchmark suite for heterogeneous computing International Symposium on Workload Characterization (IISWC)*. <https://www.researchgate.net>
- Meng, Y., Song, Y., Hui, L., & Boon, C., (2009). Empirical Near Ground Path Loss Modeling in a Forest at VHF and UHF Bands. *Antennas and Propagation*, 57(5), 1461-1468.
- Mir, G., Jun-ichi, T., & Tetsuro, I. (2013). *Radio Wave Propagation through Vegetation*. In Y. Zheng (ed), *Wave Propagation Theories and Applications*. DOI: 10.5772/52571. <https://www.intechopen.com/books/wave-propagation-theories-and-applications/radio-wave-propagation-through-vegetation>
- Moon, S., Kim, Y., Myeong, H., Kim, C., Cha, N., & Kim, D. (2011). *Implementation of smartphone environment remote control and monitoring system for Android operating system-based robot platform*. [https://www.researchgate.net/publication/254049803-Implementation\\_of\\_smartphone\\_environment\\_remote\\_control\\_and\\_monitoring\\_system\\_for\\_Android\\_operating\\_system-based\\_robot\\_platform/citation/download](https://www.researchgate.net/publication/254049803-Implementation_of_smartphone_environment_remote_control_and_monitoring_system_for_Android_operating_system-based_robot_platform/citation/download)
- Moon, S., Kim, Y., Myeong, H., Kim, C., Cha, N., & Kim, D. (2011). *Implementation of smartphone environment remote control and monitoring system for Android operating system-based robot platform*. 10.1109/URAI.2011.6145963.
- Mulla, S., Patel, A., & Heath, L. (2015). Toward A Social-Psychological Understanding of Mass Media and Fear of Crime: More Than Random Acts of Senseless Violence. In C. Derek (Ed), *Psychology of Fear, Crime and the Media*. Imprint Psychology Press. DOI <https://doi.org/10.4324/9781315779812>
- NCA. (2014). Ngorongoro Vegetation Cover. <https://www.ngorongoro-tanzania.com/ngorongoro-vegetation-cover.html>
- Ndzi, D. L., Kamarudin, L. M., Mohammad, A. A., Zakaria, A., Ahmad, R. B., Fareq, M. M. A., Shakaff, A.Y. M., & Jafaar, M. N. (2012). Vegetation attenuation measurements and modelling in plantations for wireless sensor network planning. *Progress in Electromagnetic Research B*, 36, 283-301.
- Östlin, G., Hayes, M., Kunth, D., Miguel, M. J. H., Leitherer, C., Petrosian, A., & Atek, H. (2009). The Lyman Alpha Morphology of Local Starburst Galaxies: Release of Calibrated Images. *American Astronomical Society*, 138, 1-28.

- Patrovsky, A., & Biebl, E. M. (2005). Microwave sensors for detection of wild animals during pasture mowing. *Advances in Radio Sciences*, 3, 211–217, <https://doi.org/10.5194/ars-3-211-2005>, 2005.
- PhysioLab. (2016). *Biosignal Sensing and Monitoring*. file:///C:/Users/Mr.%20Haji/Downloads/Revised Proof Physiolab.pdf
- Poonam, Y. M., & Mulge, Y. (2013). Remote temperature monitoring using LM35 sensor and intimate android user via C2DM service. *International Journal of Computer Science and Mobile Computing*, 2, 32–36.
- Rangayyan, R. M., & Reddy, N. P. (2002). Biomedical signal analysis: a case-study approach. *Annals of Biomedical Engineering*, 30(7), 983-983.
- Rebecca, N., Handcock, D. L. S., Greg, J., Bishop, H., Kym, P., Patison, T., Wark, P., Valencia, P., & Corke, C. J. O. (2009). Monitoring Animal Behaviour and Environmental Interactions Using Wireless Sensor Networks, GPS Collars and Satellite Remote Sensing. *Sensors*, 9, 3586-3603.
- Reporter, D. M. (2008). *Living with humans has taught dogs morals, say scientists*. <http://www.dailymail.co.uk/sciencetech/article-1047481/Living-humans-taught-dogs-morals-say-scientists.html>.
- Rogers, N., Seville, A., Richter, J., David, N., Savage, N., Caldeirinha, R., Shukla, A., Al-Nuaimi, M., Craig, K., Vilar, E., & Austin, J. (2002). *A generic model of 1-62 Ghz radio attenuation in vegetation*. [https://digital-library.theiet.org/content/conferences/10.1049/ic\\_20020252](https://digital-library.theiet.org/content/conferences/10.1049/ic_20020252)
- Saatchi, S., & McDonald, K. (1997). Coherent effects in microwave backscattering models for forest canopies. *Geoscience and Remote Sensing*, 35, 1032 - 1044. 10.1109/36.602545. <https://s3-us-west-2.amazonaws.com/ieeeshutpages/xplore/xplore-shut-page.html>
- SafariBookings (2013). *Weather & Climate – Ngorongoro*. <https://www.safaribookings.com/ngorongoro/climate>.
- Sandem, A., & Braastad, B. O. (2005). Effects of cow-calf separation on visible eye white and behaviour in dairy cows. *Applied Animal Behaviour Science*, 95(3), 233-239. <http://dx.doi.org/10.1016/j.applanim.2005.04.011>.

- Save The Elephants. (2018). *Tracking – Real Time Monitoring*. [http:// www. Save the elephants. org/ project/ tracking-real-time-monitoring/](http://www.save-the-elephants.org/project/tracking-real-time-monitoring/).
- Sen, A. K. (2013). *Tanzania's storied wildlife reserves could soon get a watchful, winged inhabitant: U.S. drones*. The Washington Times. U.S. [https:// www. washingtontimes. com/ news/ 2013/ jul/31/ elephants- rhinos-lions-and-drones-tanzania-consider/](https://www.washingtontimes.com/news/2013/jul/31/elephants-rhinos-lions-and-drones-tanzania-consider/)
- Seybold, C. (2015). *Calibration of fundamental diagrams for travel time predictions based on the cell transmission model*. [https:// www. semanticscholar. org/paper/ Calibration- of- fundamental- diagrams -for -travel- time- Seybold /fa1a 19b2cbbb 5c6f1c9721 de7f2e fdb43f 9a2244](https://www.semanticscholar.org/paper/Calibration-of-fundamental-diagrams-for-travel-time-Seybold/fa1a19b2cbbb5c6f1c9721de7f2efdb43f9a2244)
- Seybold, J. S. (2005). *Introduction to RF Propagation*. John Wiley & Sons: Hoboken, NJ, USA. <https://onlinelibrary.wiley.com/doi/book/10.1002/0471743690>
- Srivastava, V., Tolani, M., & Sunny, M. (2019). Crystalline-Ge<sub>2</sub>Sb<sub>2</sub>Te<sub>5</sub> for photo-detection application in near infra-red region. *Superlattices and Microstructures*, 130, 1-11.
- Tamir, T. (1967). On radio-wave propagation in forest environments. *Transactions on Antennas and Propagation*, 15(6), 806-817. doi: 10.1109/TAP.1967.1139054. [https:// ieeexplore. ieee.org/abstract/document/1139054](https://ieeexplore.ieee.org/abstract/document/1139054)
- TAWIRI. (2009). *Tanzania Wildlife Corridors-Manyara-Ngorongoro (Upper Kitete/ Selela)*. [http:// www. tzwildlifecorridors. org/ corridors/manyara-ngorongoro-upper-kitete-selela/](http://www.tzwildlifecorridors.org/corridors/manyara-ngorongoro-upper-kitete-selela/).
- Tewari, R. K., Swarup, S., & Roy, M. N. (1990). Radio wave propagation through rain forests of India. *Transactions on Antennas and Propagation*, 38, 433-449. doi 10.1109/8.52261
- Texas Instruments Incorporation. (2013). *High-Performance Analog Products*. [https:// www. ti. com](https://www.ti.com)
- Thiele, J., Osechas, O., Link, J. A. B., & Wehrle, K. (2008). *Wearable Sensor Networks for Animal Observation*. In *Medicine and Biology Conference*. <https://www.comsys.rwth-aachen.de/fileadmin/papers/2008/2008-08-Osechas-EMBC08-RatPack.pdf>
- Torraco, S., Bertoni, H., & Lang, R. (1998). Modeling tree effects on path loss in a residential environment. *Antennas and Propagation*, 46, 872-880. Doi 10.1109/8.686776.

- Tsang, T., Chen, H., Huang, C. C., & Jandhyala, V. (2001). Modeling of multiple scattering among vias in planar waveguides using Foldy–Lax equations. *Micro-Wave and Optical Technology Letters*, 31(3), 201-208. <https://doi.org/10.1002/mop.1398>
- U.S.A Government. (2014). *Official U.S. government information about the Global Positioning System (GPS) and related topics*. <http://www.gps.gov/applications/>.
- U.S.A Government. (2014). *The Global Positioning System (GPS)*. <http://www.gps.gov/systems/gps/control/>.
- Umesh, J., Pankaj, P., & Shubham, D. (2013). Overview of Wireless Sensor Network and Its Applications. *International Journal of Electronics Communication and Computer Engineering*, 4 (2), 29-32.
- UNEP. (2011). *Ngorongoro conservation area Tanzania as world conservation monitoring center*. <https://en.unesco.org/news/ngorongoro-conservation-area-united-republic-tanzania>
- University of Washington. (2013). *Center for Conservation Biology*. <http://conservationbiology.uw.edu/research-programs/tracking-poached-ivory/>.
- Van Lieverloo, R. J., Schuiling, B. F., De Boer, W. F., Lent, C. P., De Jong, B. C., & Prins, T. H. H. (2009). A comparison of faecal analysis with backtracking to determine the diet composition and species preference of the black rhinoceros (*Diceros bicornis minor*). *European Journal of Wildlife Research*, 55, 505–515. <https://doi.org/10.1007/s10344-009-0264-5>
- Verma, G. K., & Tiwary, U. S. (2014). Multimodal fusion framework: A multiresolution approach for emotion classification and recognition from physiological signal, *NeuroImage*, 102, 162-172.
- Vieira, M. A. M., Coelho, C. N., DaSilvia, D. C., & DaMata, J. M. (2003). *Survey on wireless sensor network devices. Conference on Emerging Technologies and Factory Automation. Proceedings (pp. 537-544)*. Lisbon, Portugal. doi: 10.1109/ETFA.2003.1247753.
- Vieira, M., Claudionor, D. S., & Diogenes, M. (2003). *Survey on Wireless Sensor Network Devices: Conference on Emerging Technologies and Factory Automation (pp. 537–544)*. <https://ieeexplore.ieee.org/document/1247753>



- Wall, J., Wittemyer, G., Klinkenberg, B., & Douglas-Hamilton, I. (2014). Novel opportunities for wildlife conservation and research with real-time monitoring. *Ecological Applications*, 24(4), 593-601.
- Wang, F., & Sarabandi, K. (2007). A Physics-Based Statistical Model for Wave Propagation Through Foliage. *Antennas and Propagation*, 55, 958-968. 10.1109/TAP.2007.891841.
- Weissberger, M. A. (1982). *An Initial Critical Summary of Models for Predicting the Attenuation of Radio Waves by Trees*. <https://apps.dtic.mil/sti/citations/ADA118343>
- Whitman, G., Schwering, F., & Chen, L.W. (1984). *A Theory of Millimeter Wave Propagation in Vegetation*. [https://www.researchgate.net/publication/235113732\\_A\\_Theory\\_of\\_Millimeter\\_Wave\\_Propagation\\_in\\_Vegetation/link/5563abcb08ae8c0cab36f165/download](https://www.researchgate.net/publication/235113732_A_Theory_of_Millimeter_Wave_Propagation_in_Vegetation/link/5563abcb08ae8c0cab36f165/download)
- Wildlife ACT. (2014). *Global Positioning System and VHF Tracking Collars used For Wildlife Monitoring*. <https://wildlifeact.com/blog/gps-and-vhf-tracking-collars-used-for-wildlife-monitoring>
- Wireless Wildlife. (2017). *wireless-wildlife Rhino Security, Monitoring and Management System South Africa*. <https://www.wireless-wildlife.co.za/ProductPDFs/Rhino%20-%20basic%20system%20overview.Pdf>
- Wittemyer, G., Northrup, M. J., Blanc, J., Hamilton, D. I., Omondi, P., Kenneth, P., & Burnham, P. K. (2014). Ivory poaching drives decline in African elephants. *Proceedings of the National Academy of Sciences*, 111 (36), 13117-13121. DOI: 10.1073/pnas.1403984111 <https://www.pnas.org/content/111/36/13117.short>
- World Elephant Centre. (2018). *Promoting Elephant Conservation through Research and Education*. [www.worldelephantcentre.org](http://www.worldelephantcentre.org)
- World Wildlife Fund. (2013). *Microchip to protect Rhino in Kenya*. <https://www.worldwildlife.org/>
- World Wildlife Fund. (2018). *Unprecedented Collaring Effort Aims to Protect Tanzania's Threatened Elephants*. <https://www.worldwildlife.org/press-releases/unprecedented-collaring-effort-aims-to-protect-tanzania-s-threatened-elephants>

Xudong, J., Li, S. S., & Tidrow, M. Z. (1999). Investigation of a multistack voltage-tunable four-color quantum-well infrared photodetector for mid- and long-wavelength infrared detection. *Journal of Quantum Electronics*, 35(11), 1685-1692. doi: 10.1109/3.798092.

Zhang, L. L., Alvin, S. S., Hui, Z., & Xin, L. (2010). A Distributed System for Mad-Cow Disease Monitoring and Tracking. *International Journal of Ubiquitous computing*, 1(2), 1-18.

## APPENDICES

### Appendix 1: Entry Permit to Ngorongoro Area Authority



## Ngorongoro Conservation Area Authority

Ref: NCAA/D/240/Vol. XXIII/100

Date: June 23, 2015

DIRECTOR GENERAL,  
TAWIRI  
P. O. Box 661  
**ARUSHA, TANZANIA**

Att. Dr. Angela Mwakatobe Fax 027 2548240

RE: **ENTRY PERMIT FOR MR. ERICK ALPHONCE MASSAWE**

Reference is made your letter dated 23<sup>rd</sup> June 2015 on the above subject.

An entry Permit is issued to **ERICK ALPHONCE MASSAWE** a PHD student holding a COSTECH and TAWIRI permit number TWRI/RS-331/VOL.II/2013/02 , issued on 23<sup>rd</sup> June 2015 to enter the Ngorongoro Conservation Area on research titled ***“Development of an intelligent tracking system for monitoring Rhinos and Elephants”***

This permit is valid from **23<sup>rd</sup> June 2015 to 22<sup>nd</sup> June 2016.**

During his research findings and data collection, he will be accompanied and visited by his Supervisors **Prof. Kisangiri Michael (NM-AIST) and Dr. Shubi Kaijage (NM-AIST)**. This permit allows them to **enter the area** at any time during the period of this project.

All other NCAA regulations should be obeyed during the operations.

We wish you all the best.

**NGORONGORO CONSERVATION AREA AUTHORITY**

A. W. Melita  
for: **CONSERVATOR OF NGORONGORO**

Copy: Lodoare Gate

Naabi Gate

Manager Ecological Monitoring  
NCAA

Head office: P.O. Box 1 Ngorongoro Crater Tel 255 27 253 7019, 255 27 253 7006 Fax 255 27 7007  
Mobile: 255 748 306 222 Direct line 255 27 253 7046  
E-mail: [conservator\\_hq@habari.co.tz](mailto:conservator_hq@habari.co.tz) or [ncaa\\_faru@cybernet.co.tz](mailto:ncaa_faru@cybernet.co.tz)  
Liason Office: P. O. Box 776 Tel 253 27 250 3339 Fax 255 27 250 3339 Telegram: NGOROASILIA

***All correspondence should be addressed to the Conservator of Ngorongoro***

## Appendix 2: Sample Coding

```
sketch_nov27a | Arduino 1.6.4
File Edit Sketch Tools Help

sketch_nov27a $
char output[20]; char time[20]; char status[20]; char latitude[20]; char direct1[20]; char longitude[20]; char direct2[20]; char speed6[20]; char course6[20]; char date[20]; char mode[20];
int received=0,los=0;
int time1;
char dbase[]="+255789000609: database";
char drone[]="+255768000609: drone";
char mobileapp[]="+255768000609: mobile app";
char mobilephone[]="+255657567533: mobile phone";
char *hrs="00";
char *latitude1="00.0000"; char latitude2[20];
char *longitude1="00.0000"; char longitude2[20];
char *sec_lat="0.0000";
char *sec_lon="0.0000";
float lat; float sec_lat1;
float lon; float sec_lon1;
float speed1;

unsigned int temp;
unsigned int gsr;

int exited;

char LOS[50];

char bpm[5];int bpm1;

int ecg;
unsigned long a,b;
int ecg_signal[2000];
```

```
sketch_nov27a | Arduino 1.6.4
File Edit Sketch Tools Help

sketch_nov27a $
{
  Serial.println("AT+CMGF=1");
  delay(200);
  Serial.print("AT+CMGS=");Serial.print((char)34);Serial.print(phone_no);Serial.println((char)34);
  delay(200);
}
void sendGSM_dbase()
{
  Serial.print("time:");Serial.print(time1); Serial.print((char)58); Serial.print(time[2]); Serial.print(time[3]); Serial.print((char)58); Serial.print(time[4]); Serial.println(time[5]);
  Serial.print("latitude:");Serial.print(latitude[0]);Serial.print(latitude[1]);Serial.print((char)223);Serial.print(latitude[2]); Serial.print(latitude[3]);Serial.print((char)39);Serial.print
  Serial.println(direct1);
  Serial.print("longitude:");Serial.print(longitude[0]);Serial.print(longitude[1]);Serial.print(longitude[2]);Serial.print((char)223);Serial.print(longitude[3]);Serial.print(longitude[4]);Serial.pri
  Serial.println(direct2);
  Serial.print("speed:");Serial.print(speed1);Serial.println("km/h");
  Serial.print("date:");Serial.print(date[0]);Serial.print(date[1]);Serial.print((char)47);Serial.print(date[2]);Serial.print(date[3]);Serial.print((char)47);Serial.print("20");Serial.print(da
  Serial.print("temperature:");Serial.print(temp);Serial.print((char)223);Serial.println("C");
  Serial.print("skin conductance:");Serial.print(gsr);Serial.println("S");
  Serial.print("heart rate:");Serial.print(bpm1);Serial.println("bpm");
  Serial.print("ecg data:");
  for(b=0;b<1900;b++)
  {
    Serial.print(ecg_signal[b]);
    Serial.print((char)32);
  }
  Serial.println();
  if(los=='1')
  Serial.println("horns in line of site");
  else if(los=='2')
```

```

sketch_nov27a $
else if(los=='2')
Serial.println("horns out of line of site");
else{}
if(exited==1)
Serial.println("animal exited or in danger");
else
Serial.println("animal in normal condition");
Serial.println((char)26);
delay(500);
}

void sendGSM_mobphone()
{
Serial.print("time:");Serial.print(time1); Serial.print((char)58); Serial.print(time[2]); Serial.print(time[3]); Serial.print((char)58); Serial.print(time[4]); Serial.println(time[5]);
Serial.print("latitude:");Serial.print(latitude[0]);Serial.print(latitude[1]);Serial.print((char)223);Serial.print(latitude[2]); Serial.print(latitude[3]);Serial.print((char)39);Serial.print
Serial.println(direct1);
Serial.print("longitude:");Serial.print(longtude[0]);Serial.print(longtude[1]);Serial.print(longtude[2]);Serial.print((char)223);Serial.print(longtude[3]);Serial.print(longtude[4]);Serial.pri
Serial.println(direct2);
Serial.print("speed:");Serial.print(speed1);Serial.println("km/h");
Serial.print("date:");Serial.print(date[0]);Serial.print(date[1]);Serial.print((char)47);Serial.print(date[2]);Serial.print(date[3]);Serial.print((char)47);Serial.print("20");Serial.print(da
Serial.print("temperature:");Serial.print(temp);Serial.print((char)223);Serial.println("C");
Serial.print("skin conductance:");Serial.print(gsr);Serial.println("S");
Serial.print("heart rate:");Serial.print(bpm1);Serial.println("bpm");
if(los=='1')
Serial.println("horns in line of site");
else if(los=='2')
Serial.println("horns out of line of site");
else{}
}

```

```

sketch_nov27a $
else
Serial.println("animal in normal condition");
Serial.println((char)26);
delay(500);
}

void sendGSM_dron()
{
Serial.print("time:");Serial.print(time1); Serial.print((char)58); Serial.print(time[2]); Serial.print(time[3]); Serial.print((char)58); Serial.print(time[4]); Serial.println(time[5]);
Serial.print("latitude:");Serial.print(latitude[0]);Serial.print(latitude[1]);Serial.print((char)223);Serial.print(latitude[2]); Serial.print(latitude[3]);Serial.print((char)39);Serial.print
Serial.println(direct1);
Serial.print("longitude:");Serial.print(longtude[0]);Serial.print(longtude[1]);Serial.print(longtude[2]);Serial.print((char)223);Serial.print(longtude[3]);Serial.print(longtude[4]);Serial.pri
Serial.println(direct2);
Serial.print("speed:");Serial.print(speed1);Serial.println("km/h");
Serial.print("date:");Serial.print(date[0]);Serial.print(date[1]);Serial.print((char)47);Serial.print(date[2]);Serial.print(date[3]);Serial.print((char)47);Serial.print("20");Serial.print(da
Serial.println((char)26);
delay(500);
}

void hour_conv()
{
hrs[0]=time[0]; hrs[1]=time[1];
time1=atoi(hrs);
time1=time1+3;
if(time1>24)
{
time1=time1-24;
}
}

```

```
sketch_nov27a | Arduino 1.6.4
File Edit Sketch Tools Help

sketch_nov27a $
}
else if(time1==24)
{
time1=00;
}
}

void latitude_conv()
{
latitude1[0]=latitude[2]; latitude1[1]=latitude[3]; latitude1[2]=latitude[4]; latitude1[3]=latitude[5]; latitude1[4]=latitude[6]; latitude1[5]=latitude[7]; latitude1[6]=latitude[8];

lat=atof(latitude1);

strcpy(latitude2,latitude);

sec_lat[0]='0'; sec_lat[1]=latitude2[4]; sec_lat[2]=latitude2[5]; sec_lat[3]=latitude2[6]; sec_lat[4]=latitude2[7];
sec_lat1=atof(sec_lat);
sec_lat1*=60;
}

void longtude_conv()
{
longtude1[0]=longtude[3]; longtude1[1]=longtude[4]; longtude1[2]=longtude[5]; longtude1[3]=longtude[6]; longtude1[4]=longtude[7]; longtude1[5]=longtude[8]; longtude1[6]=longtude[9];
lon=atof(longtude1);

strcpy(longtude2,longtude);

sec_lon[0]='0'; sec_lon[1]=longtude2[5];sec_lon[2]=longtude2[6];sec_lon[3]=longtude2[7];sec_lon[4]=longtude2[8];
```

```
sketch_nov27a | Arduino 1.6.4
File Edit Sketch Tools Help

sketch_nov27a $
sec_lon[0]='0'; sec_lon[1]=longtude2[5];sec_lon[2]=longtude2[6];sec_lon[3]=longtude2[7];sec_lon[4]=longtude2[8];
sec_lon1=atof(sec_lon);
sec_lon1*=60;
}

void speed_conv()
{
speed1=atof(speedG);
speed1*=1.652;
}

void read_temp()
{
temp=analogRead(A1);
temp=temp/2-1;
}

void read_GSR()
{
gsr=analogRead(A2);
gsr=(gsr+1)/(4-1);
}

void get_bpm()
{
if(Serial1.available()>0)
{
Serial1.readBytesUntil((char)13,bpm,6);
```

```
sketch_nov27a | Arduino 1.6.4
File Edit Sketch Tools Help

sketch_nov27a $
    Serial1.readBytesUntil((char)13,bpm,6);
    bpm1=atoi(bpm);
}
}

void check_los()
{
    if(Serial2.available()>0)
        los=Serial2.read();
}

void send_mobphone()
{
    exited=0;
    if(((bpm1>70)&&(bpm1<200))&&((gsr>150)&&(gsr<300))&&((temp>40)&&(temp<60))|| (los=='2'))
    {
        if(((bpm1>70)&&(bpm1<200))&&((gsr>150)&&(gsr<300))&&((temp>40)&&(temp<60)))
        {
            exited=1;
        }
        gsm_init(dron);
        sendGSM_dron();
        gsm_init(mobphone);
        sendGSM_mobphone();
    }
}

void read_ecg()
```

```
sketch_nov27a | Arduino 1.6.4
File Edit Sketch Tools Help

sketch_nov27a $

void read_ecg()
{
    for(a=0;a<=1900;a++)
    {
        ecg=analogRead(A0);
        delay(5);
        ecg_signal[a]=ecg;
    }
}

void readGPS()
{
    check_los();
    get_bpm();
    Serial.readBytesUntil(',',output,20);
    if((output[0]=='G')&&(output[1]=='P')&&(output[2]=='R')&&(output[3]=='M')&&(output[4]=='C'))
    {
        Serial.readBytesUntil(',',time,20);
        Serial.readBytesUntil(',',status,20);
        Serial.readBytesUntil(',',latitude,20);
        Serial.readBytesUntil(',',direct1,20);
        Serial.readBytesUntil(',',longitude,20);
        Serial.readBytesUntil(',',direct2,20);
        Serial.readBytesUntil(',',speedG,20);
        Serial.readBytesUntil(',',courseG,20);
        Serial.readBytesUntil(',',date,20);
        Serial.readBytesUntil(',',mode,20);
    }
}
```



```
sketch_nov27a $  
  
if(status[0]!='A')  
{  
  hour_conv();  
  latitude_conv();  
  longitude_conv();  
  speed_conv();  
  read_temp();  
  read_GSR();  
  read_ecg();  
  send_mobphone();  
  gsm_init(dbase);  
  sendGSM_dbase();  
  gsm_init(mobapp);  
  sendGSM_dbase();  
}  
else  
{  
  Serial.println("invalid data");  
}  
received=0;  
}  
}  
  
void setup()  
{  
  delay(3000);  
  Serial.begin(9600);  
}
```

```
sketch_nov27a $  
  Serial.println("invalid data");  
}  
received=0;  
}  
}  
  
void setup()  
{  
  delay(3000);  
  Serial.begin(9600);  
  Serial1.begin(9600);  
  Serial2.begin(9600);  
  delay(100);  
}  
  
void loop()  
{  
  if(Serial.available(>0)  
  {  
    received=Serial.read();  
    if(received=='$')  
    {  
      readGPS();  
    }  
  }  
}
```



## RESEARCH OUTPUTS

### (i) Research Articles

Massawe, A., Kisangiri, M., Kaijage, S., & Seshaiyer, P. (2017). Design and Analysis of Smart Sensing System for Animal Emotions Recognition. *International Journal of Computer Applications*, 169 (11), 0975 – 8887.

Massawe, A., Kisangiri, M., Kaijage, S., & Seshaiyer, P. (2017). An intelligent real-time wireless sensor network tracking system for monitoring rhinos and elephants in Tanzania national parks: A review. *International Journal of Advanced Smart Sensor Network Systems*, 7 (4), 1-11. DOI:10512/ijassin.2017.7401

### (ii) Poster Presentation